

HIAB iX.258 HiDUO

iX. 258 HiDuo EP-5

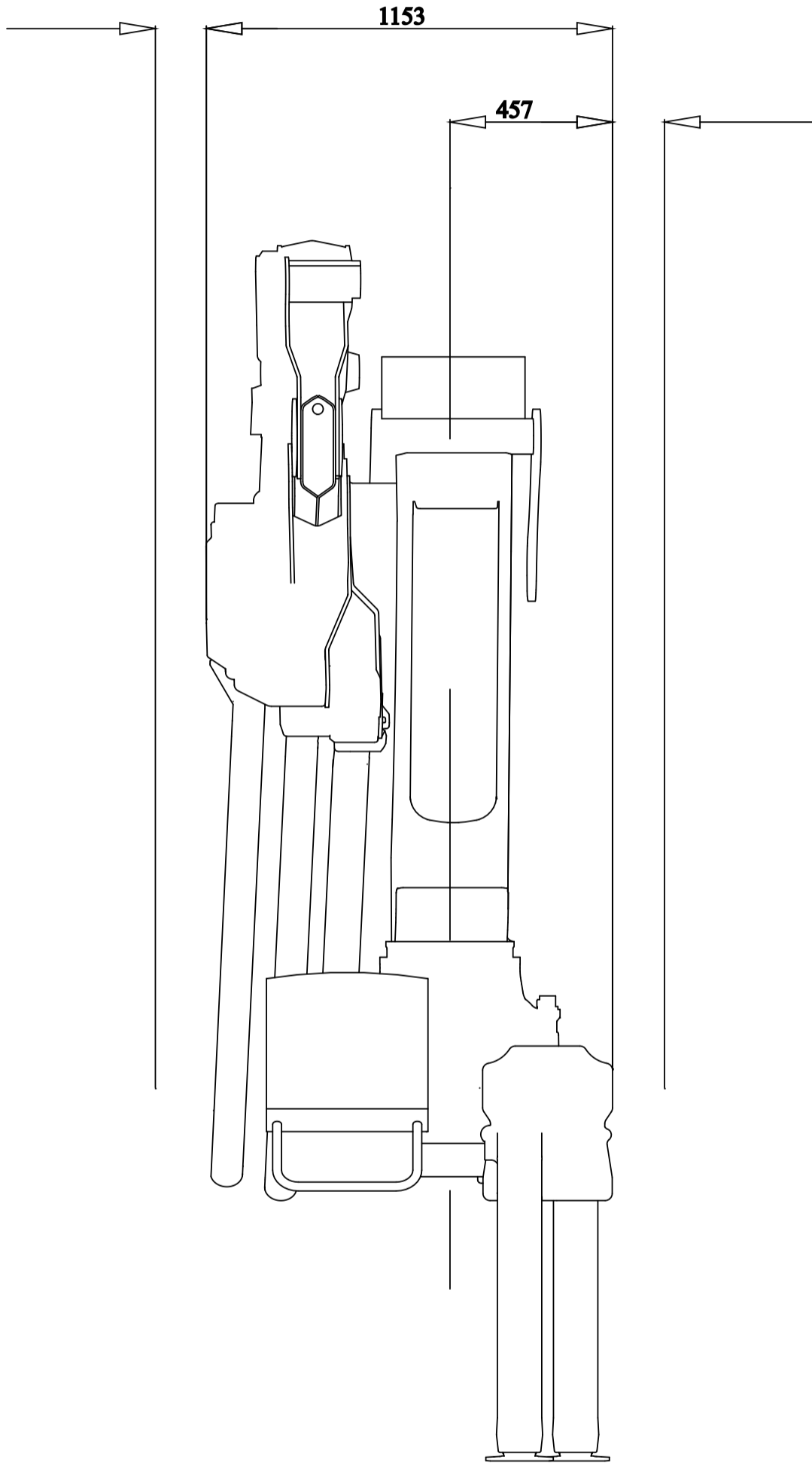

iX. 258 HiDuo EP-5
Side View Folded (Metric)



iX. 258 HiDuo EP-5

Side View Unfolded Close In Area (Metric)

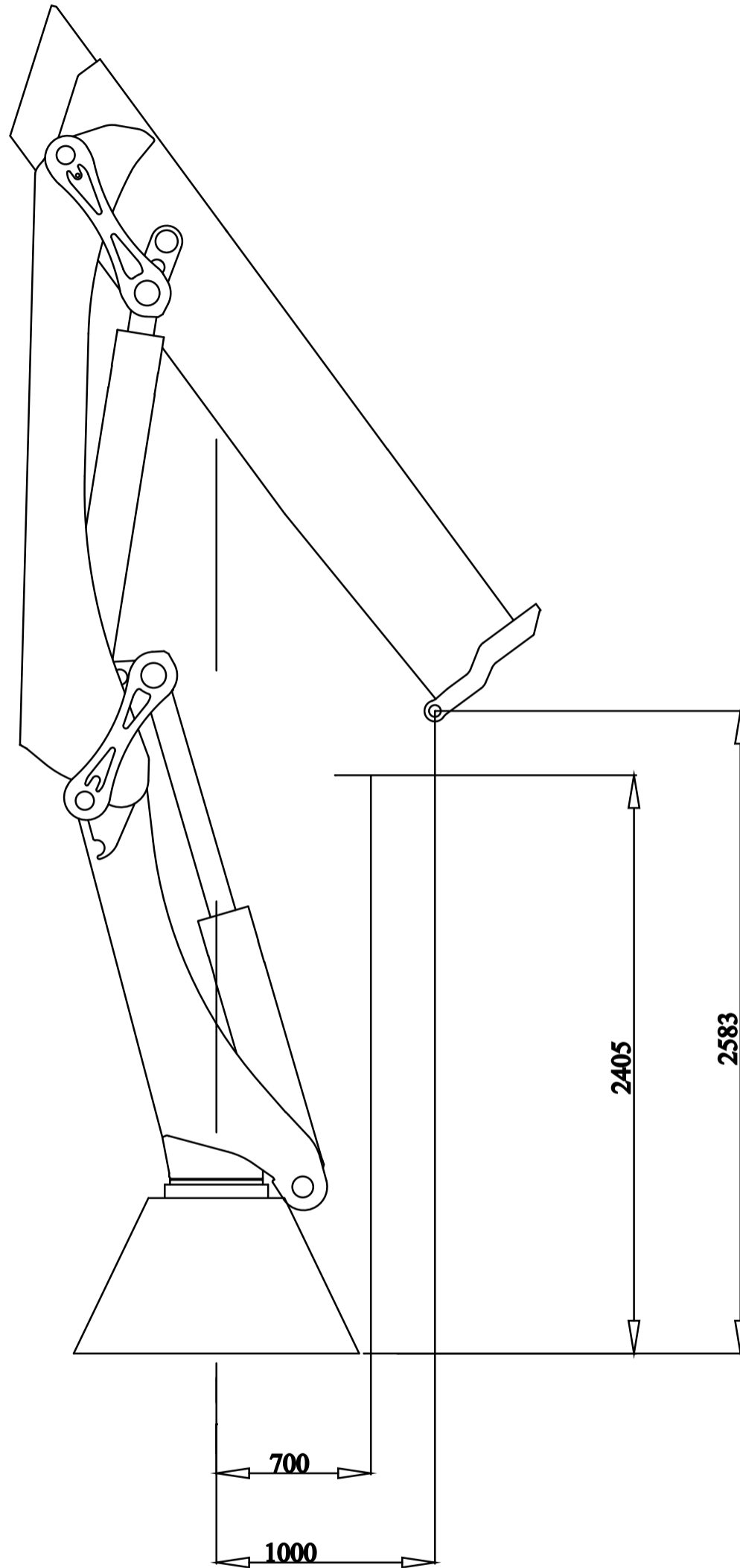

iX. 258 HiDuo EP-5

Side View Unfolded Stretched (Metric)

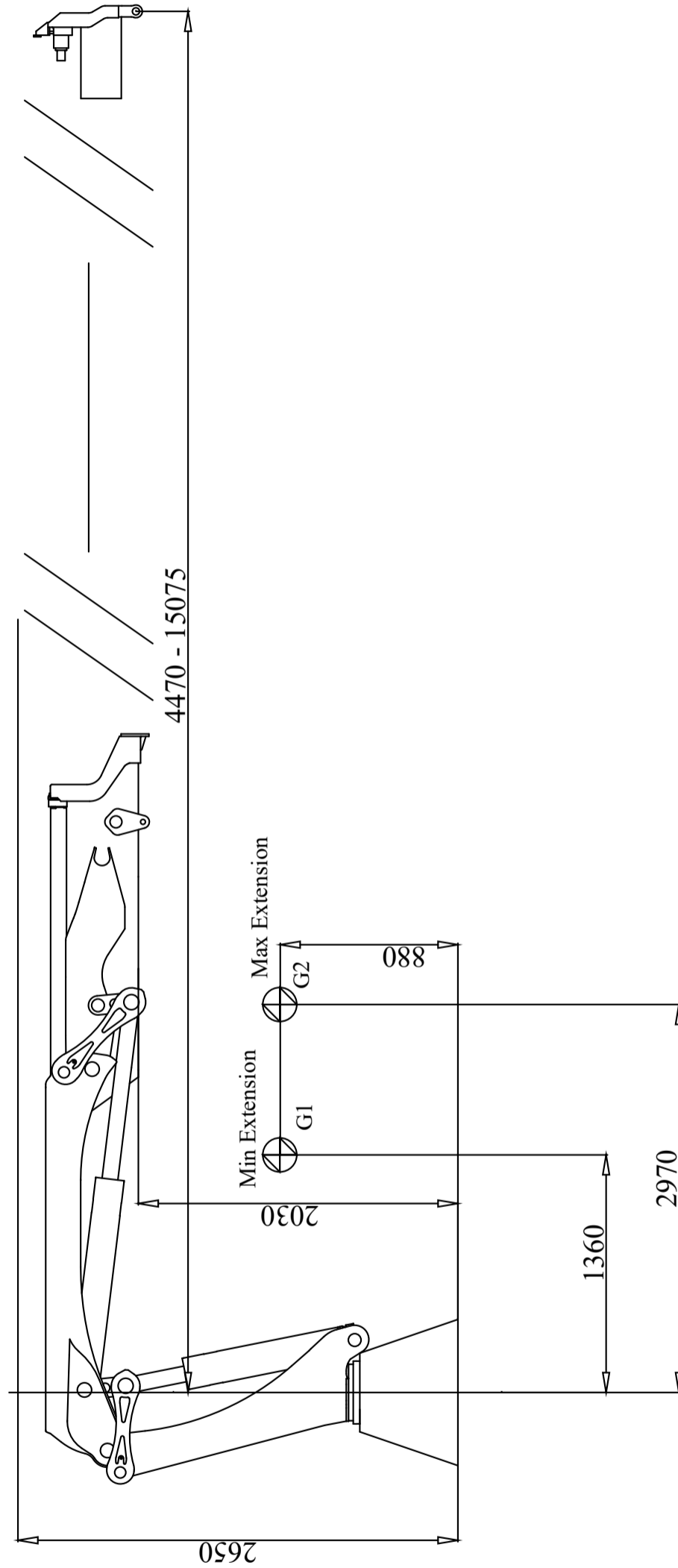

iX. 258 HiDuo EP-5

Top View (Metric)

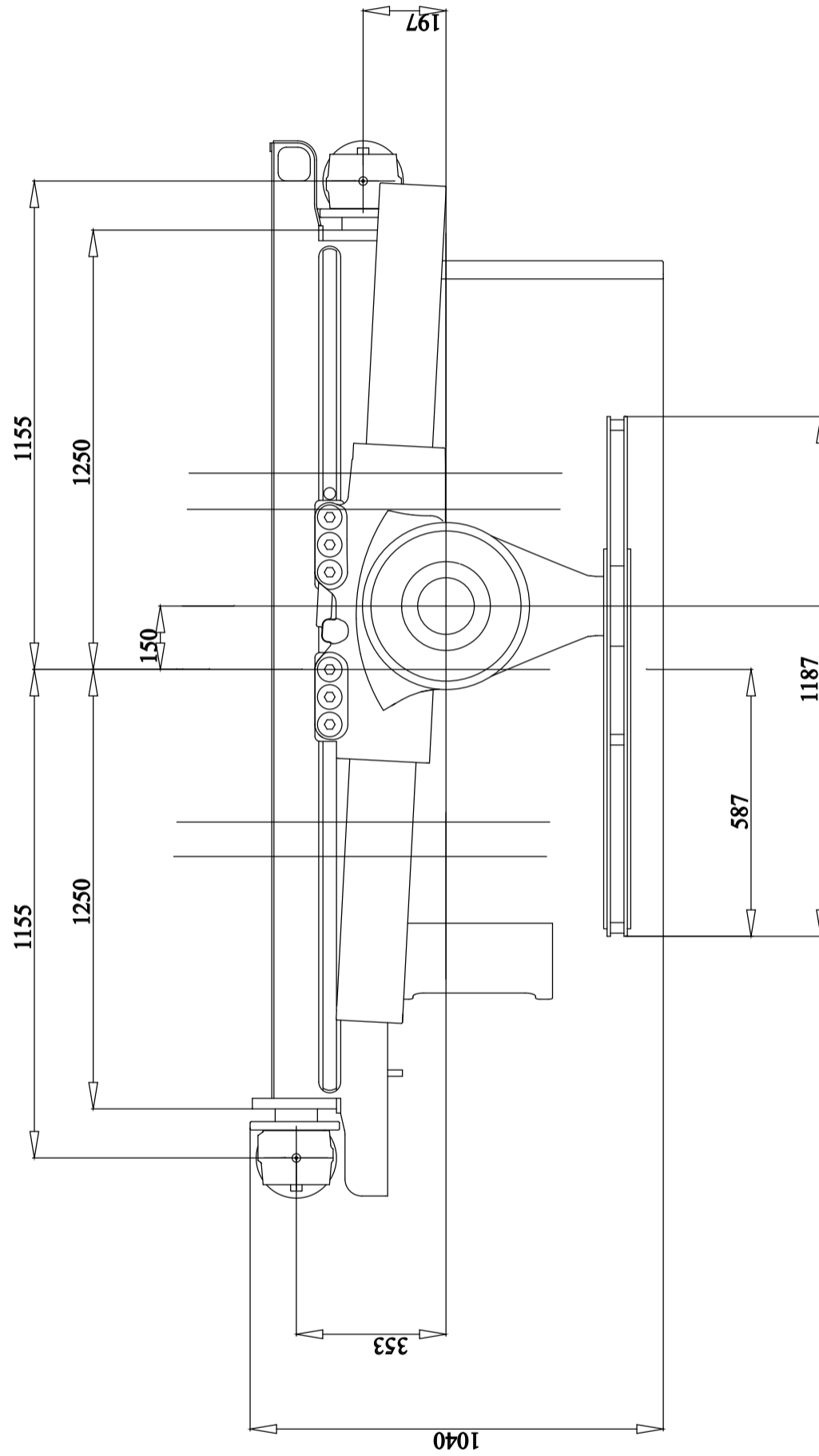

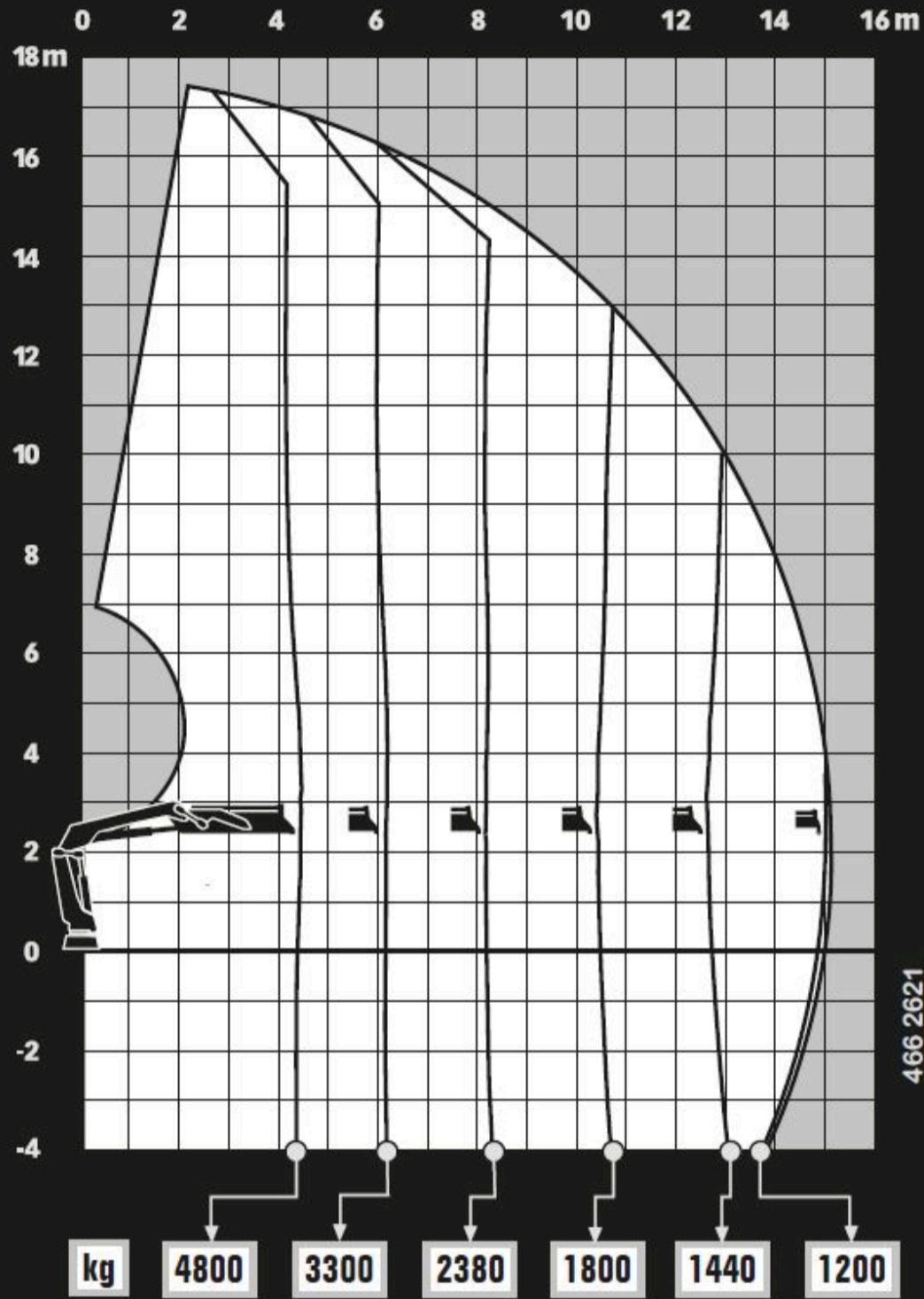
 **HIAB iX 258 HIDUO EP-5**

466 2621

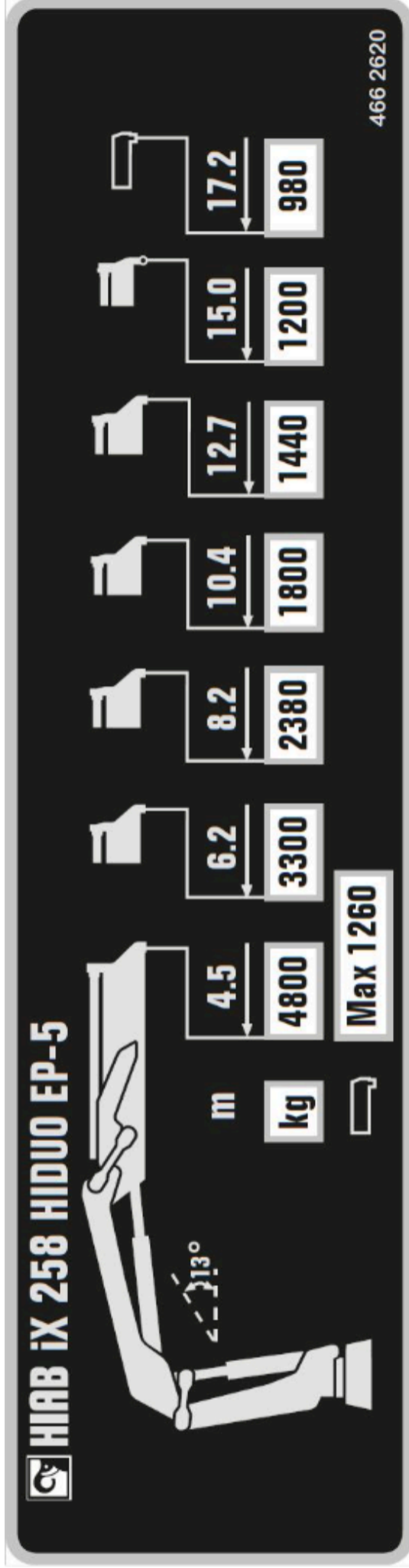

IX. 258 HiDuo EP-5

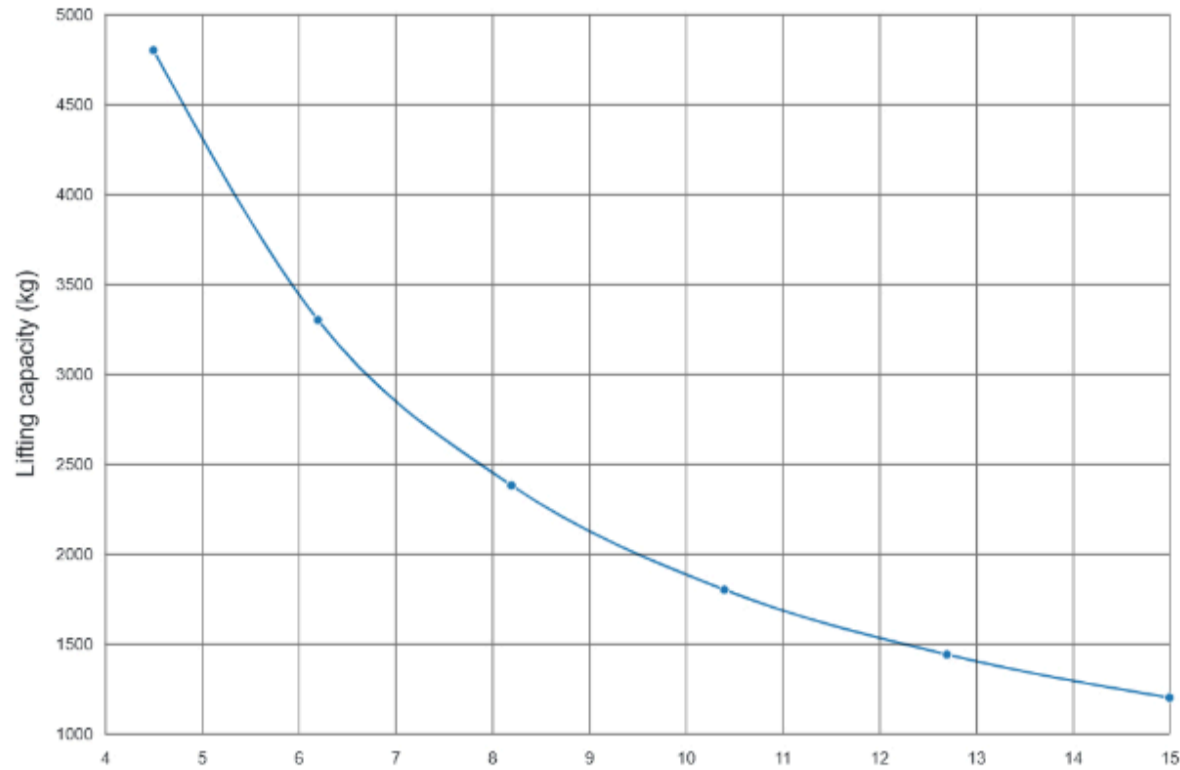

Outreach

Description	Unit	Value
Standard Outreach 2 (SOR2) - Standard load at std outreach with ADC 2 (SLC_ADC2)	m - kg	4.5 - 4800
Standard Outreach 3 (SOR3) - Standard load at std outreach with ADC 3 (SLC_ADC3)	m - kg	6.2 - 3300
Standard Outreach 4 (SOR4) - Standard load at std outreach with ADC 4 (SLC_ADC4)	m - kg	8.2 - 2380
Standard Outreach 5 (SOR5) - Standard load at std outreach with ADC 5 (SLC_ADC5)	m - kg	10.4 - 1800
Standard Outreach 6 (SOR6) - Standard load at std outreach with ADC 6 (SLC_ADC6)	m - kg	12.7 - 1440
Standard Outreach 7 (SOR7) - Standard load at std outreach with ADC 7 (SLC_ADC7)	m - kg	15.0 - 1200
HydOut Reach Std (HORS)	m	15.1
Hyd Boom Ext (HBE)	m	10.6
Manual Outreach 1 (MOR1)	m	17.2
Manual load capacity 1 (MLC1)	kg	980.0

Lifting capacity

Description	Unit	Value
Max Dynamic Moment (Mdyn)	kNm	294.0
Lifting Capacity (LC_ADC_kNm)	kNm	211.1
Lifting Capacity (LC_ADC_kNm)	tm	21.5
Lifting Height Above Installation Level Hydr (HAIL-H) / Lifting Height Above Installation Level Manual (HAIL-M)	m / m	17.7 / 19.9
Stress calculation moment (Mstat)	kNm	382.0

Oil and tank

Description	Unit	Value
Oil In Tank (TankVol)	l	200.0
Tank Capacity (TankCap)	l	235.0

Slewing

Description	Unit	Value
Slewing Angle (SlewAng)	°	410
Max slope viable at full capacity (MaxAng)	°	5.0
Slewing Torque (SlewTorq)	kNm	28.3
Slewing Speed (SlewSp)	°/s	15.0
Hyd Boom Ext Time Out - regenerative (HET-Reg-Out) - Hyd Boom Ext Time In - regenerative (HET-Reg-In)	s - s	19 - 17
Lift Speed (LiftSp)	m/s	2.6
Max force on ground from stabiliser leg, max from all configurations (P_max)		209.9

Dimensions

Description	Unit	Value
Height fold. (3-1)	mm	2393.0
Ref 3-2 width folded- heartcrane frame left (3-3b)	mm	1253.0
Install.space need. (4-1)	mm	1153.0

Weights

Description	Unit	Value
Weight of Crane (Weight)	kg	2940.0
add weight of frame attachment (add_WHT_FA)	kg	55.5
add weight of oil cooler (add_WHT_OC)	kg	31.9
Weight with legs (add_WHT_STAB)	kg	454.0
Weight of tank incl. Oil 0,87 kg/liter (add_WHT_TANK)	kg	217.0

Total weight = 3698.4 kg