

HIAB iX.228 HiDUO

iX. 228 HiDuo E-6



iX. 228 HiDuo E-6

Front View Folded (Metric)

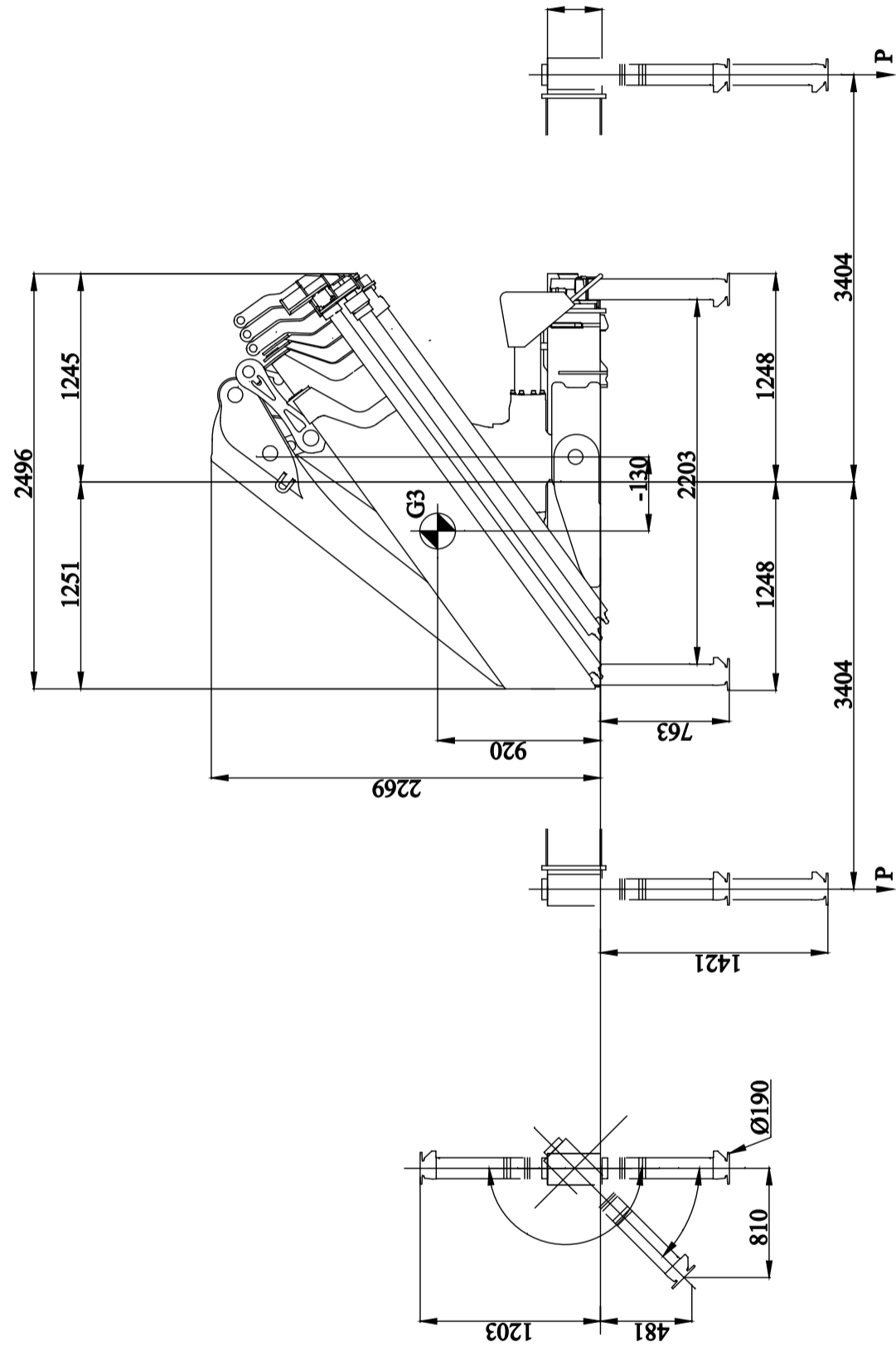

iX. 228 HiDuo E-6
Side View Folded (Metric)

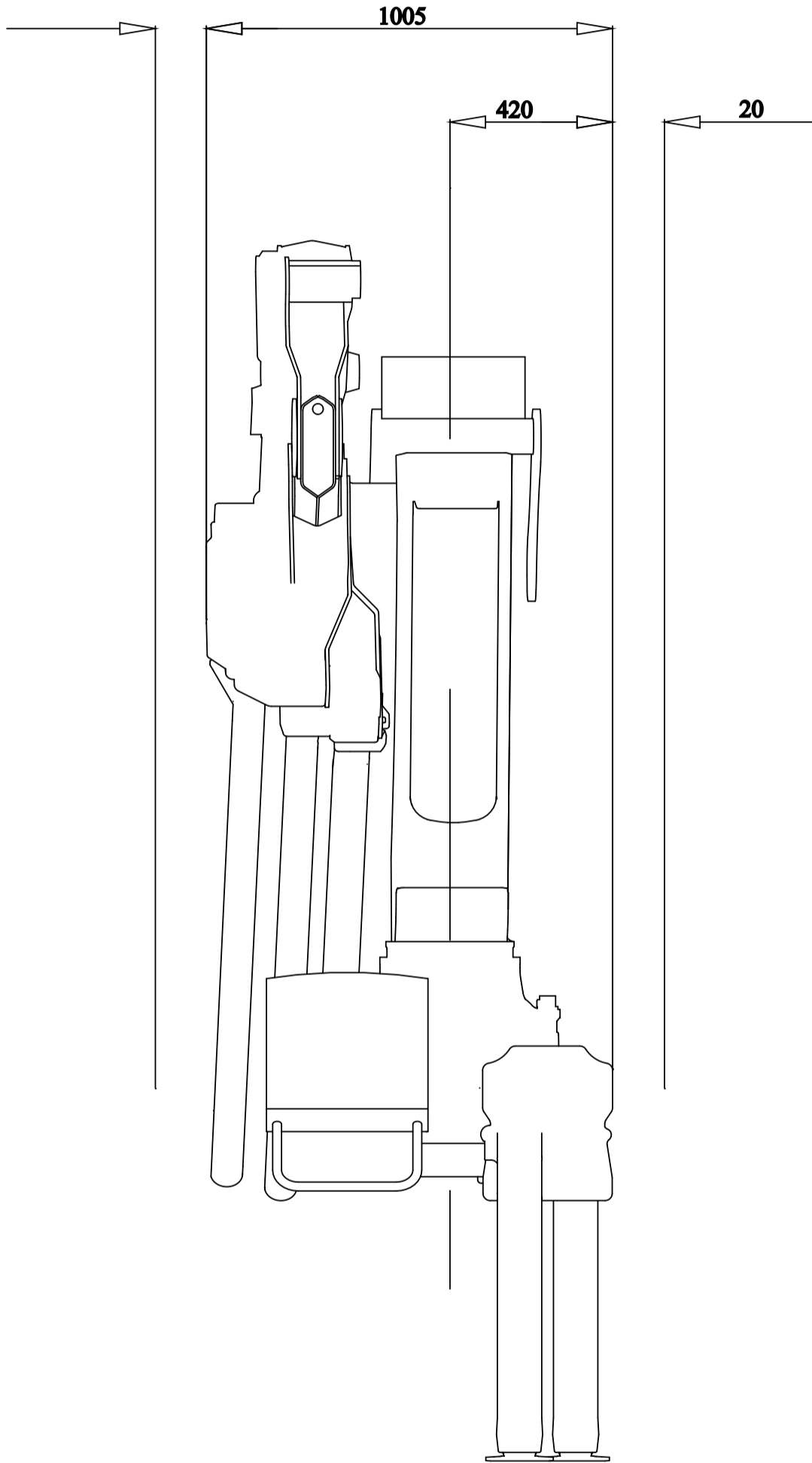

iX. 228 HiDuo E-6

Side View Unfolded Close In Area (Metric)

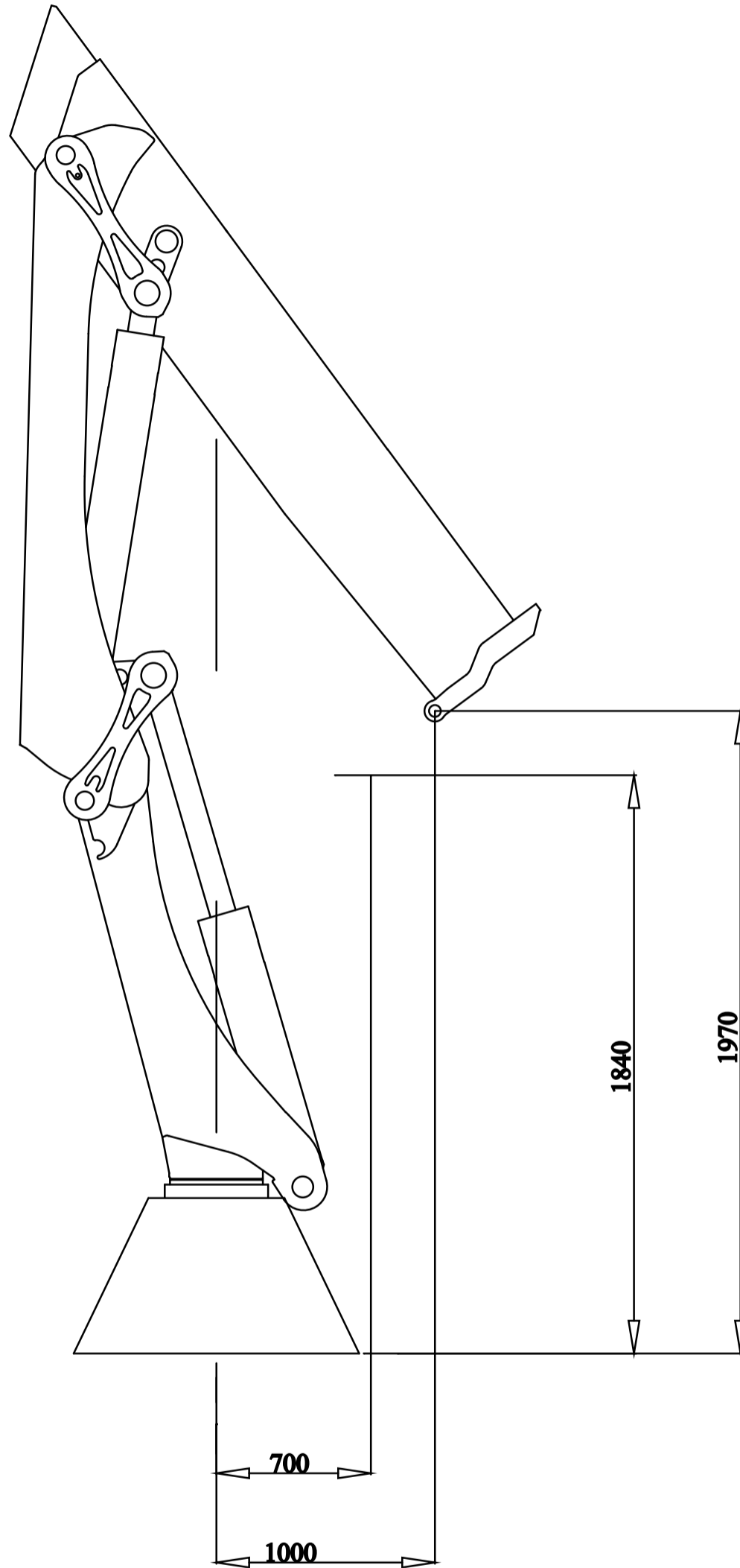

ix. 228 HiDuo E-6

Side View Unfolded Stretched (Metric)

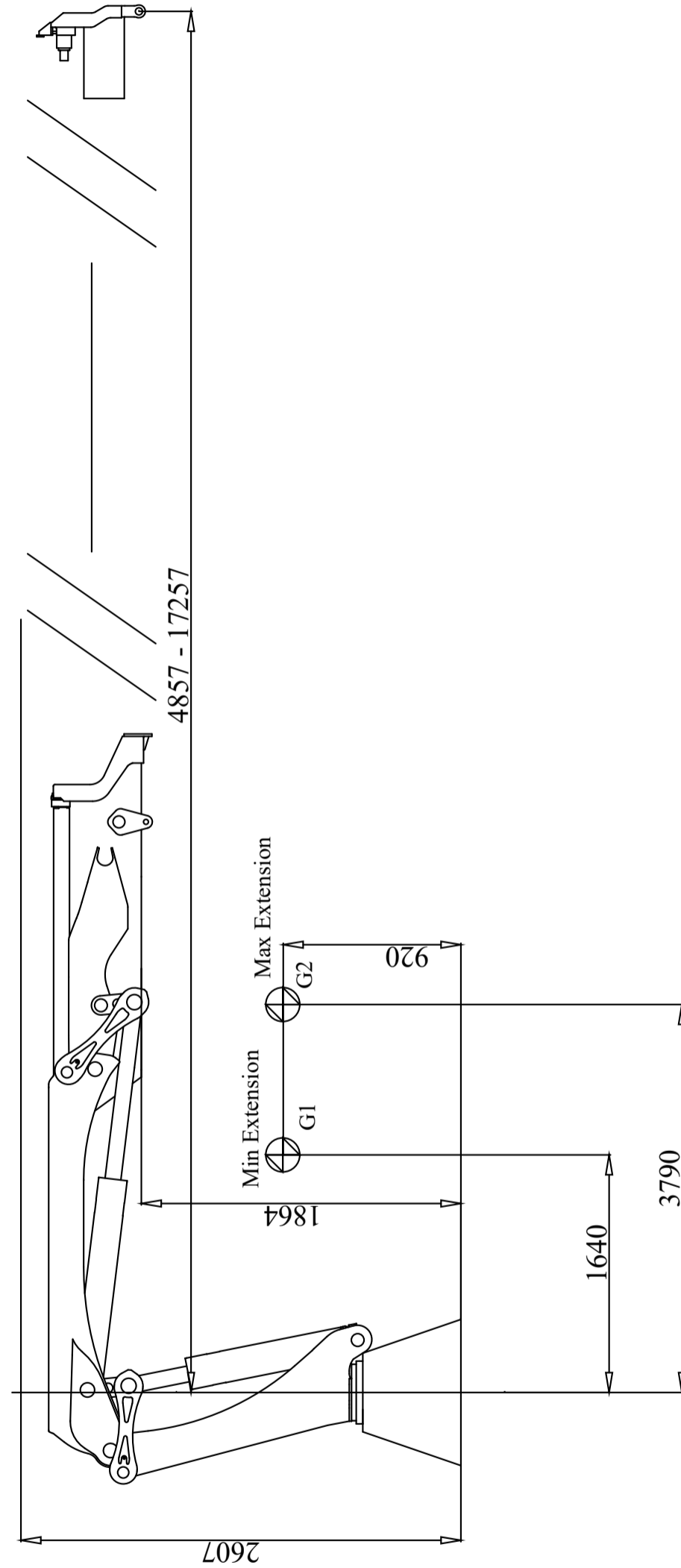

iX. 228 HiDuo E-6

Top View (Metric)

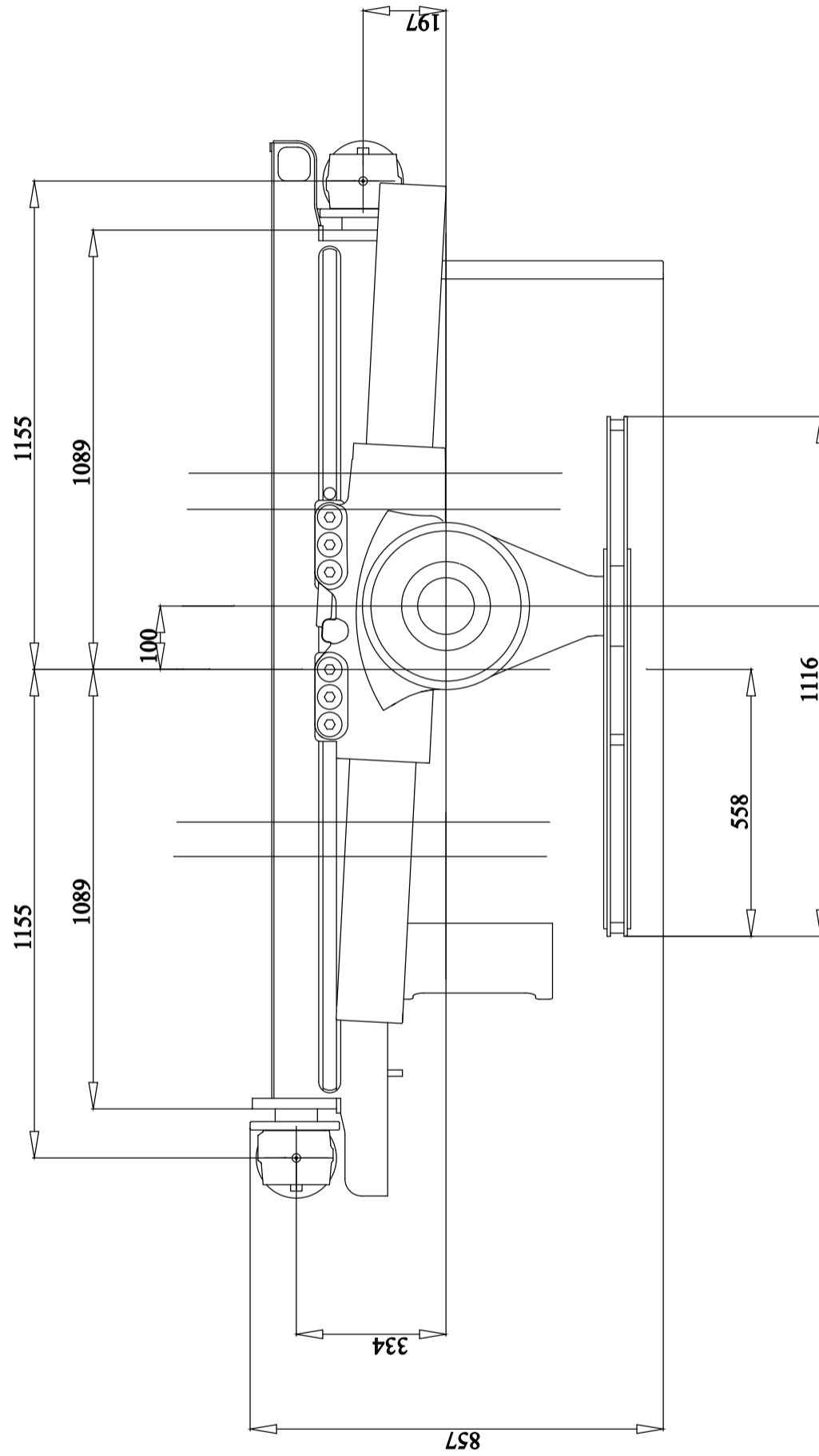

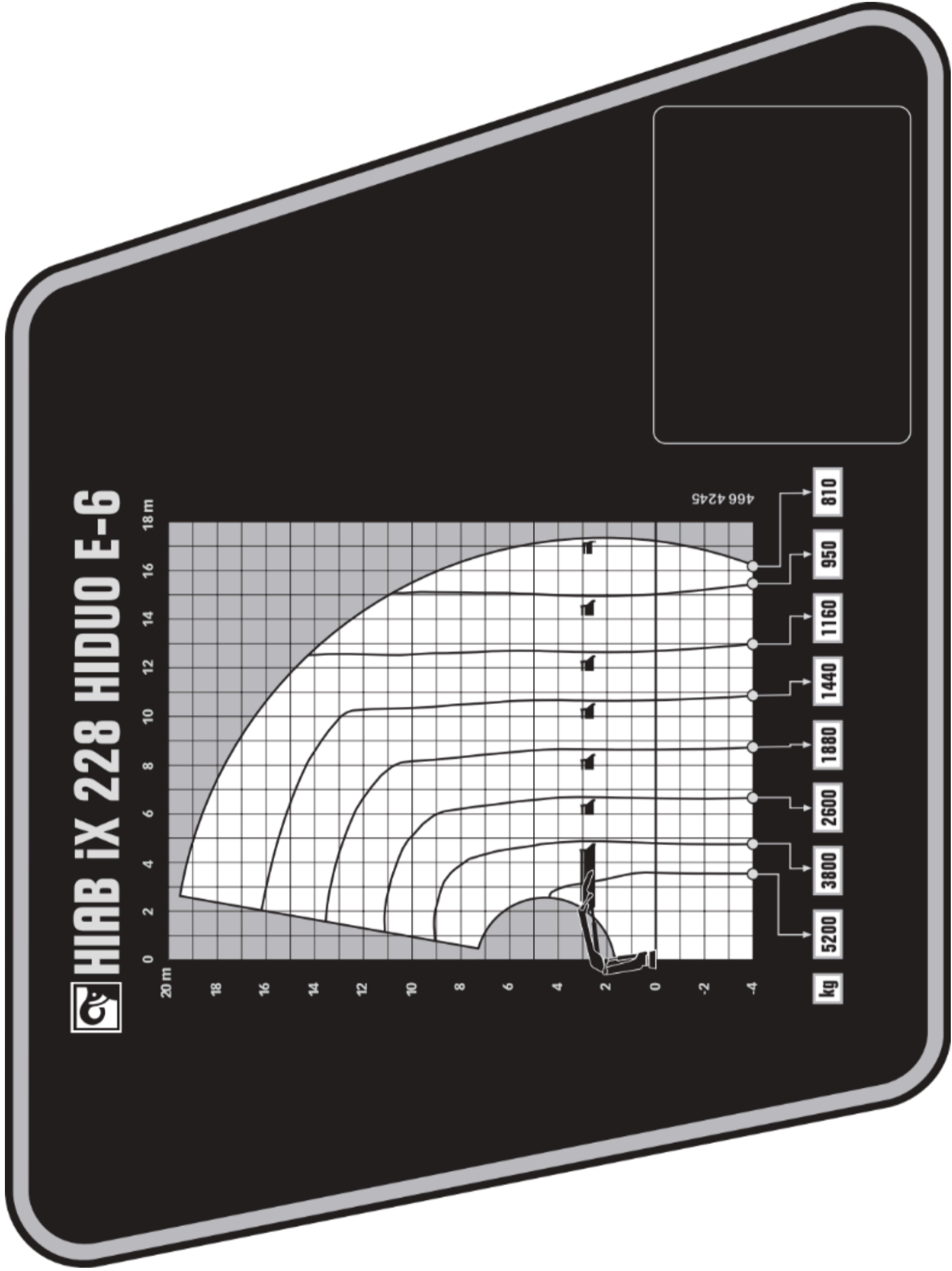

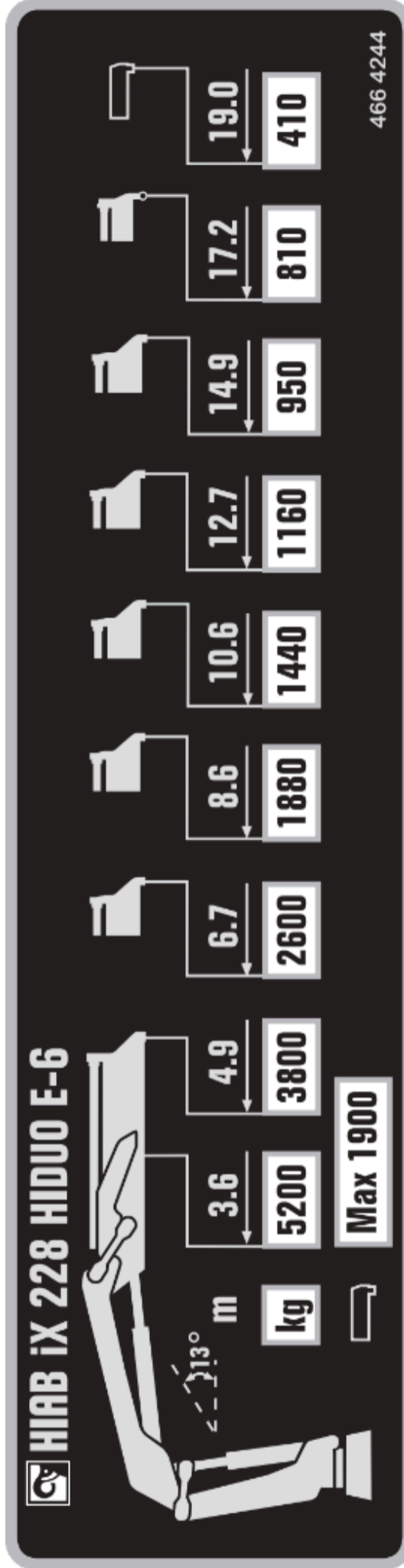

IX. 228 HiDuo E-6

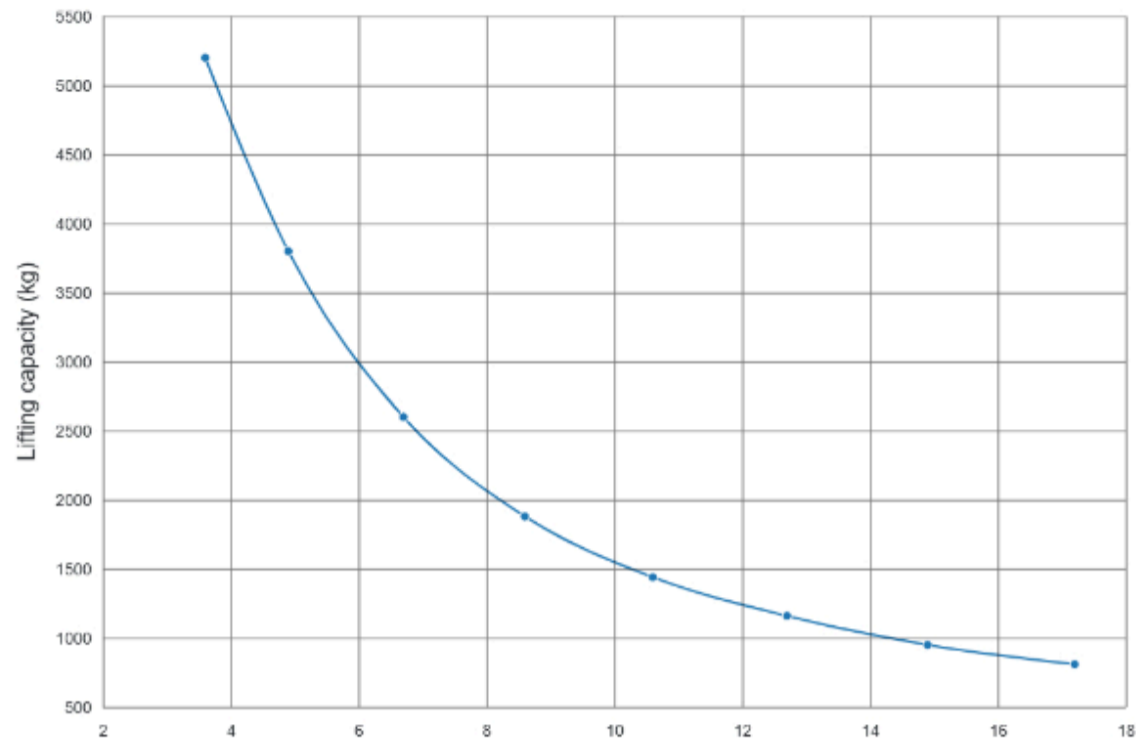

Outreach

Description	Unit	Value
Standard Outreach 1 (SOR1) - Standard load at std outreach with ADC 1 (SLC_ADC1)	m - kg	3.6 - 5200
Standard Outreach 2 (SOR2) - Standard load at std outreach with ADC 2 (SLC_ADC2)	m - kg	4.9 - 3800
Standard Outreach 3 (SOR3) - Standard load at std outreach with ADC 3 (SLC_ADC3)	m - kg	6.7 - 2600
Standard Outreach 4 (SOR4) - Standard load at std outreach with ADC 4 (SLC_ADC4)	m - kg	8.6 - 1880
Standard Outreach 5 (SOR5) - Standard load at std outreach with ADC 5 (SLC_ADC5)	m - kg	10.6 - 1440
Standard Outreach 6 (SOR6) - Standard load at std outreach with ADC 6 (SLC_ADC6)	m - kg	12.7 - 1160
Standard Outreach 7 (SOR7) - Standard load at std outreach with ADC 7 (SLC_ADC7)	m - kg	14.9 - 950
Standard Outreach 8 (SOR8) - Standard load at std outreach with ADC 8 (SLC_ADC8)	m - kg	17.2 - 810
HydOut Reach Std (HORS)	m	17.3
Hyd Boom Ext (HBE)	m	12.4
Manual Outreach 1 (MOR1)	m	19.0
Manual load capacity 1 (MLC1)	kg	410.0

Lifting capacity

Description	Unit	Value
Max Dynamic Moment (Mdyn)	kNm	254.0
Lifting Capacity (LC_ADC_kNm)	kNm	182.5
Lifting Capacity (LC_ADC_kNm)	tm	18.6
Lifting Height Above Installation Level Hydr (HAIL-H) / Lifting Height Above Installation Level Manual (HAIL-M)	m / m	19.8 / 21.6
Stress calculation moment (Mstat)	kNm	332.0

Oil and tank

Description	Unit	Value
Rec OilFlow Lo (Flow-Lo) - Rec OilFlow Hi (Flow-Hi)	l/min - l/min	65 - 75
Work Pressure (WP)	MPa	32.9
Oil In Tank (TankVol)	l	150.0
Tank Capacity (TankCap)	l	175.0

Slewing

Description	Unit	Value
Slewing Angle (SlewAng)	°	415
Max slope viable at full capacity (MaxAng)	°	5.0
Slewing Torque (SlewTorq)	kNm	28.3
Slewing Speed (SlewSp)	°/s	16.0
Hyd Boom Ext Time Out - regenerative (HET-Reg-Out) - Hyd Boom Ext Time In - regenerative (HET-Reg-In)	s - s	18 - 17
Lift Speed (LiftSp)	m/s	2.9
Max force on ground from stabiliser leg, max from all configurations (P_max)		171.7

Dimensions

Description	Unit	Value
Height fold. (3-1)	mm	2269.0
Ref 3-2 width folded- heartcrane frame left (3-3b)	mm	1245.0
Install.space need. (4-1)	mm	1005.0

Weights

Description	Unit	Value
Weight of Crane (Weight)	kg	2575.0
add weight of frame attachment (add_WHT_FA)	kg	41.0
add weight of oil cooler (add_WHT_OC)	kg	23.0
Weight with legs (add_WHT_STAB)	kg	422.3
Weight of tank incl. Oil 0,87 kg/liter (add_WHT_TANK)	kg	167.0
		Total weight = 3228.3 kg