



X-HIDUO 108 E-5

The ideal performance model within the HIAB range of loader crane products. Remote controlled loader crane. CE marked. A non CE version is also available. 10,3 Tm range capacity loader crane.

The HIAB X-HIDUO 108 is an 'optimal performance' light segment loader crane. HiDuo control system is the best price-performance remote controlled system you can choose, assuring high levels of safety matched to many functions that make any job easy. Take advantage of the many options and functions that support and protect your everyday work and business. The crane's outreach from 5,5m to 14,3m gives you the needed flexibility for carrying out jobs day after day, as a reliable partner. WARRANTY All HIAB loader cranes are backed by an industry-leading two-year warranty, with an optional third year available. Steel parts are covered by a five-year warranty or up to 100,000 load cycles, ensuring a continuous working life for your investment. The special nDurance paint protection finish further contributes to making the crane look and last longer.

Lifting capacity	450 - 3400 kg
Outreach	14 m
Weight	1843 kg

X-HIDUO 108 E-5

Front View Folded (Metric)

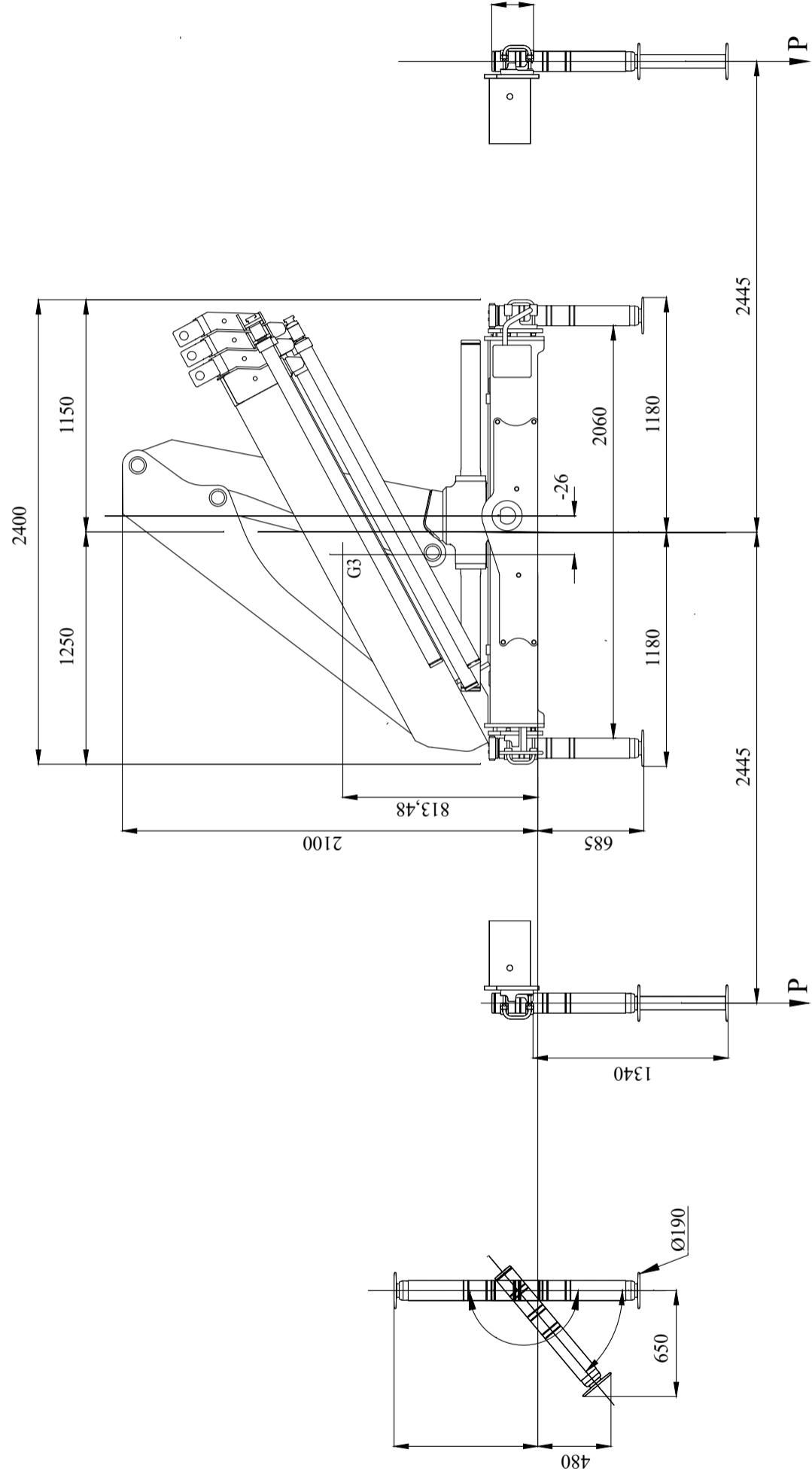

X-HIDUO 108 E-5

Side View Folded (Metric)

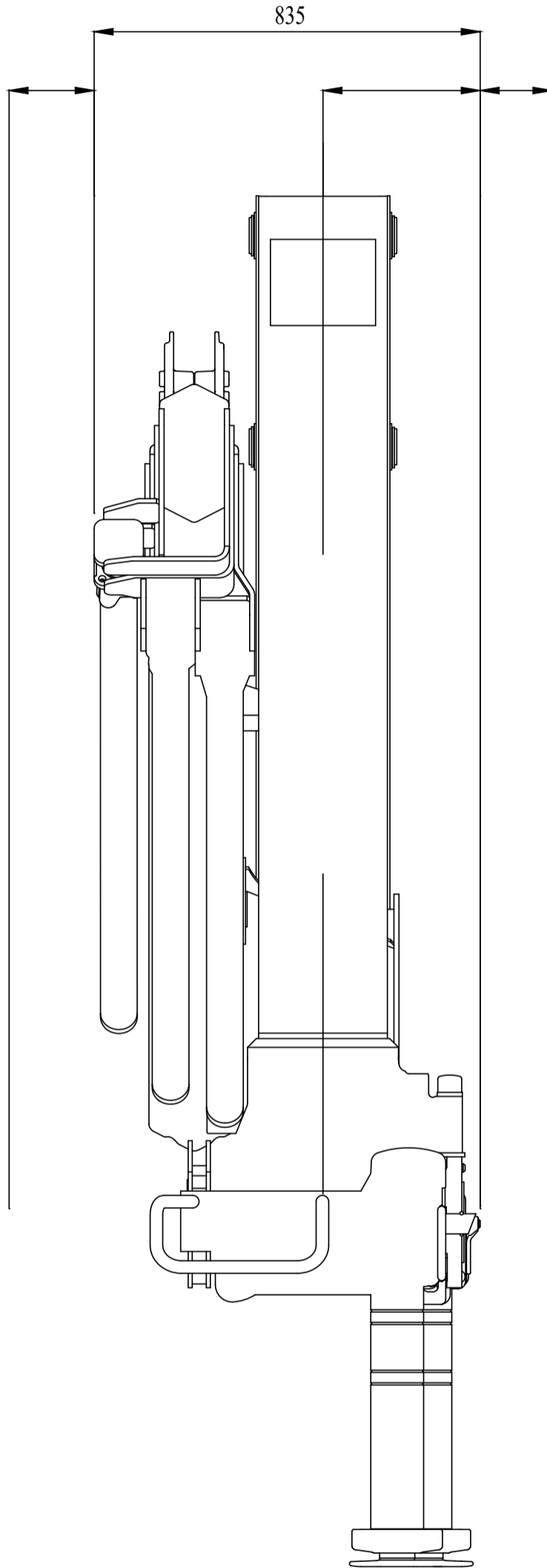

X-HIDUO 108 E-5

Side View Unfolded Close In Area (Metric)

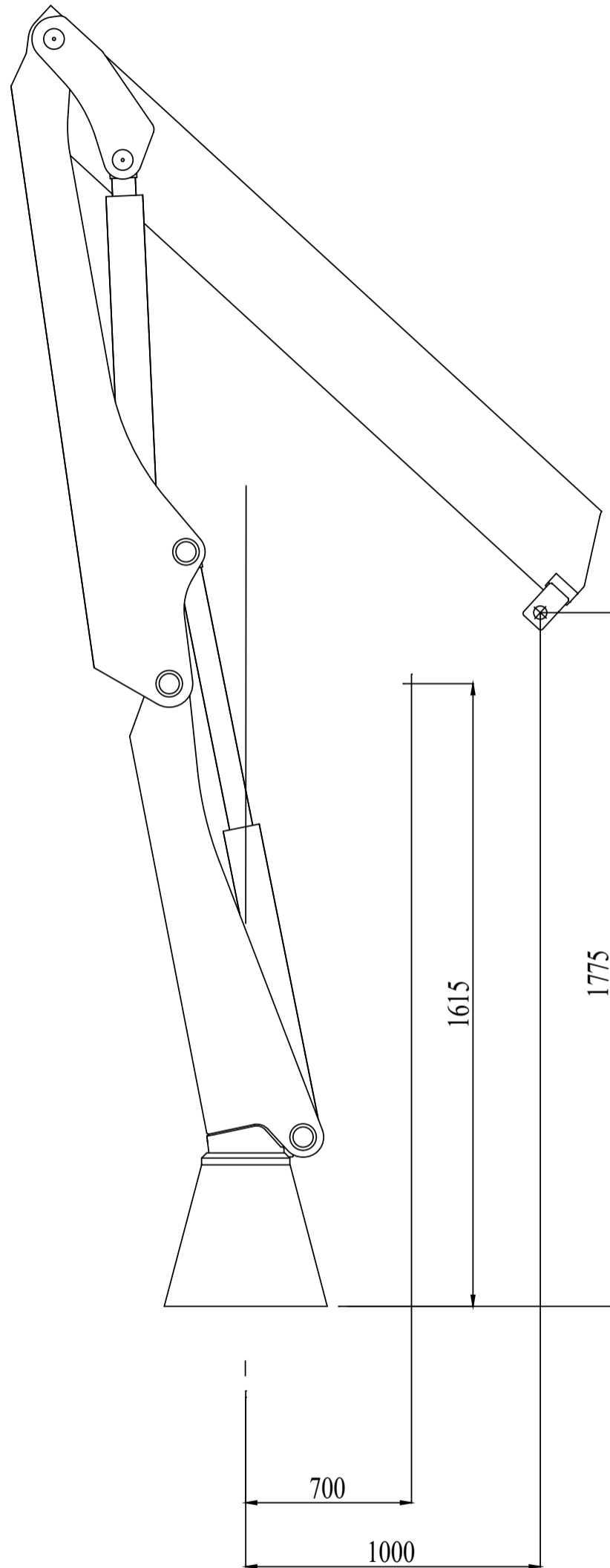

X-HIDUO 108 E-5

Side View Unfolded Stretched (Metric)

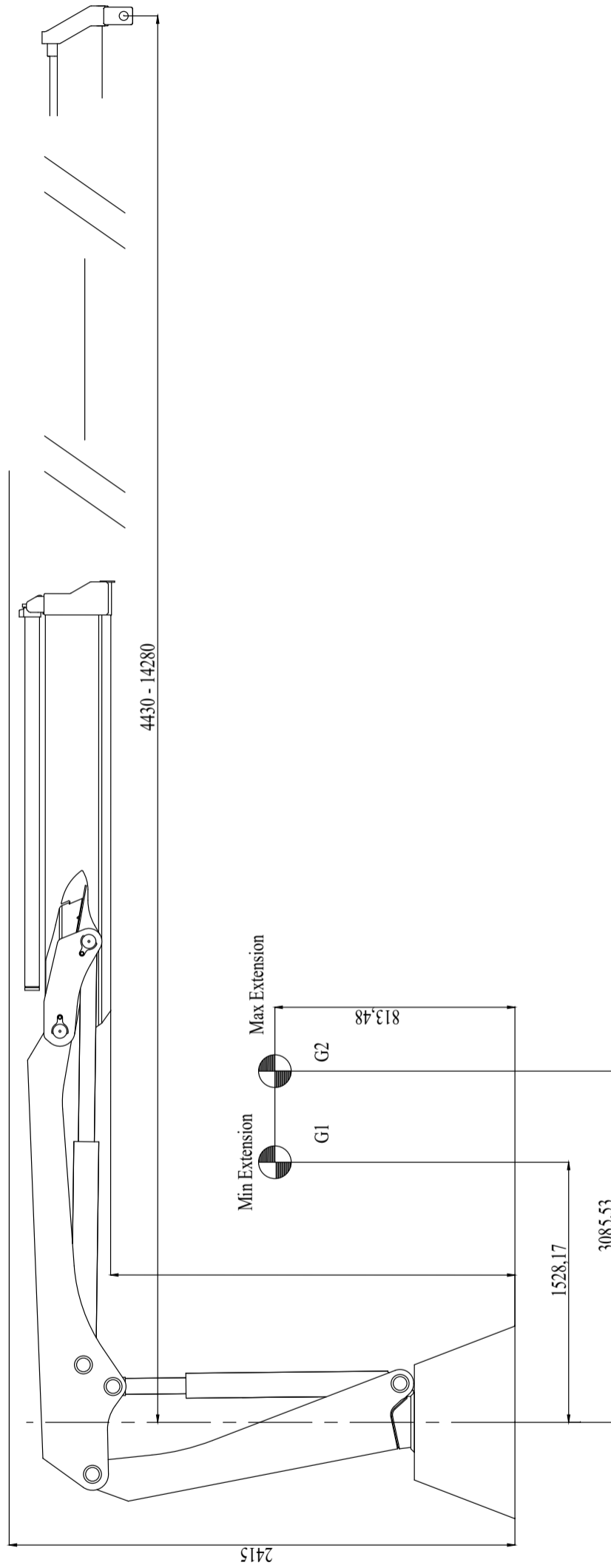

X-HIDUO 108 E-5

Top View (Metric)

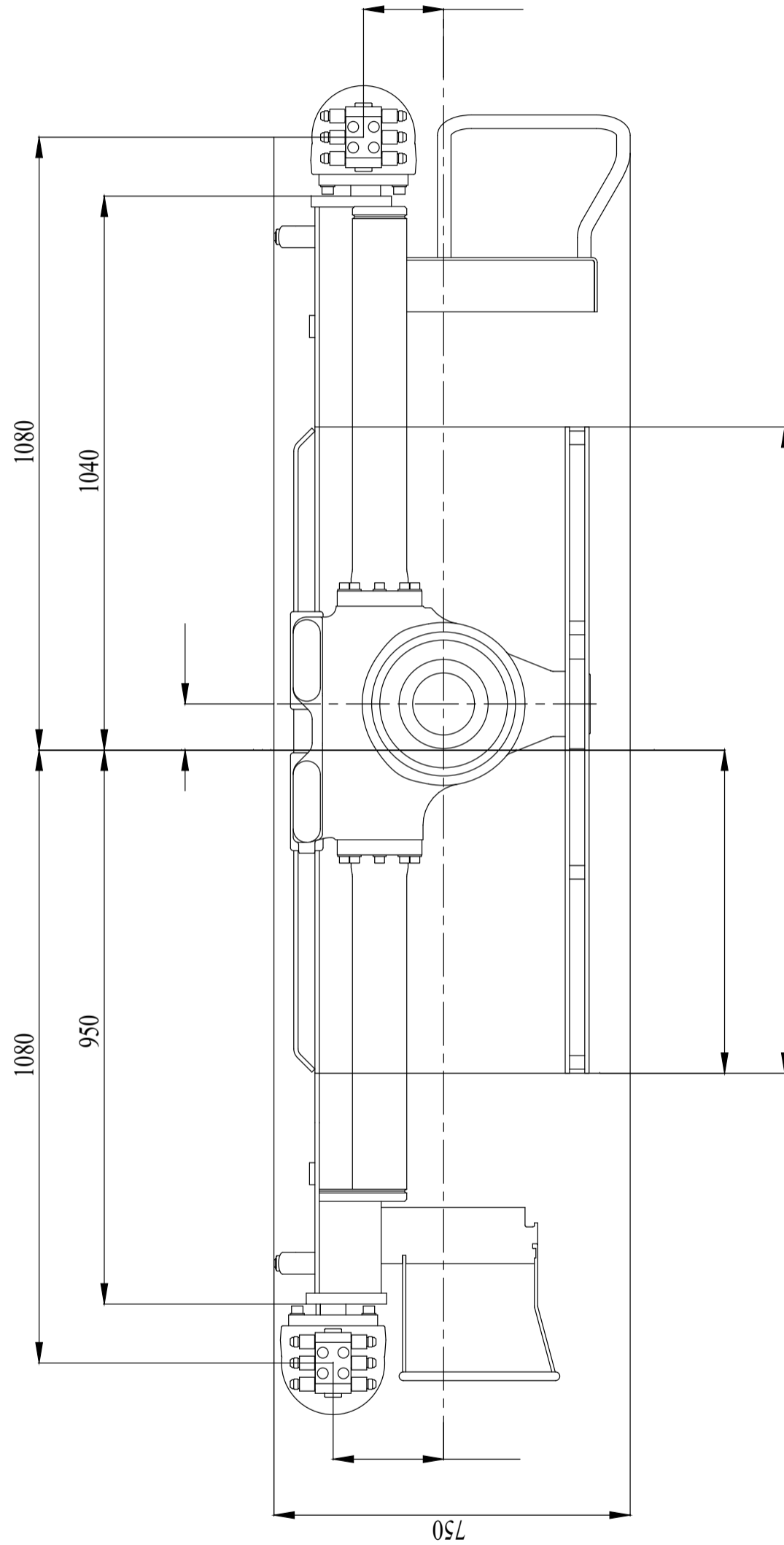

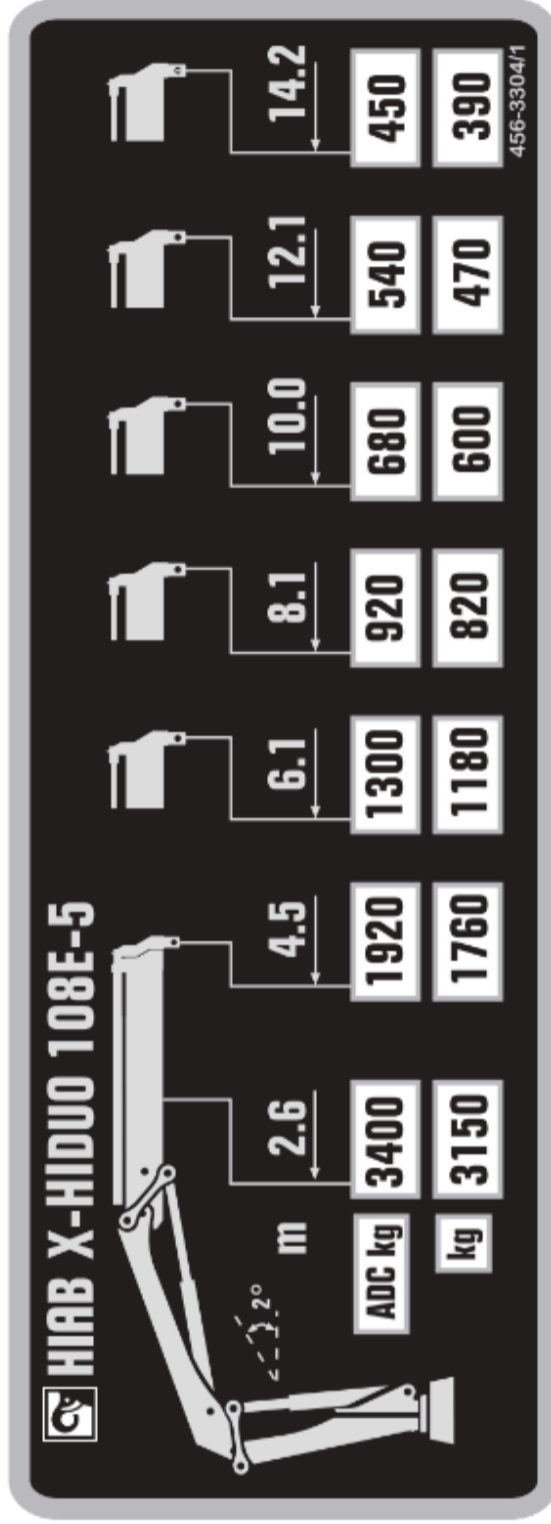



HIAB X-HIDUO 108E-5

0 1 2 3 4 5 6 7 8 9 10 11 12 13 14 15m

17m

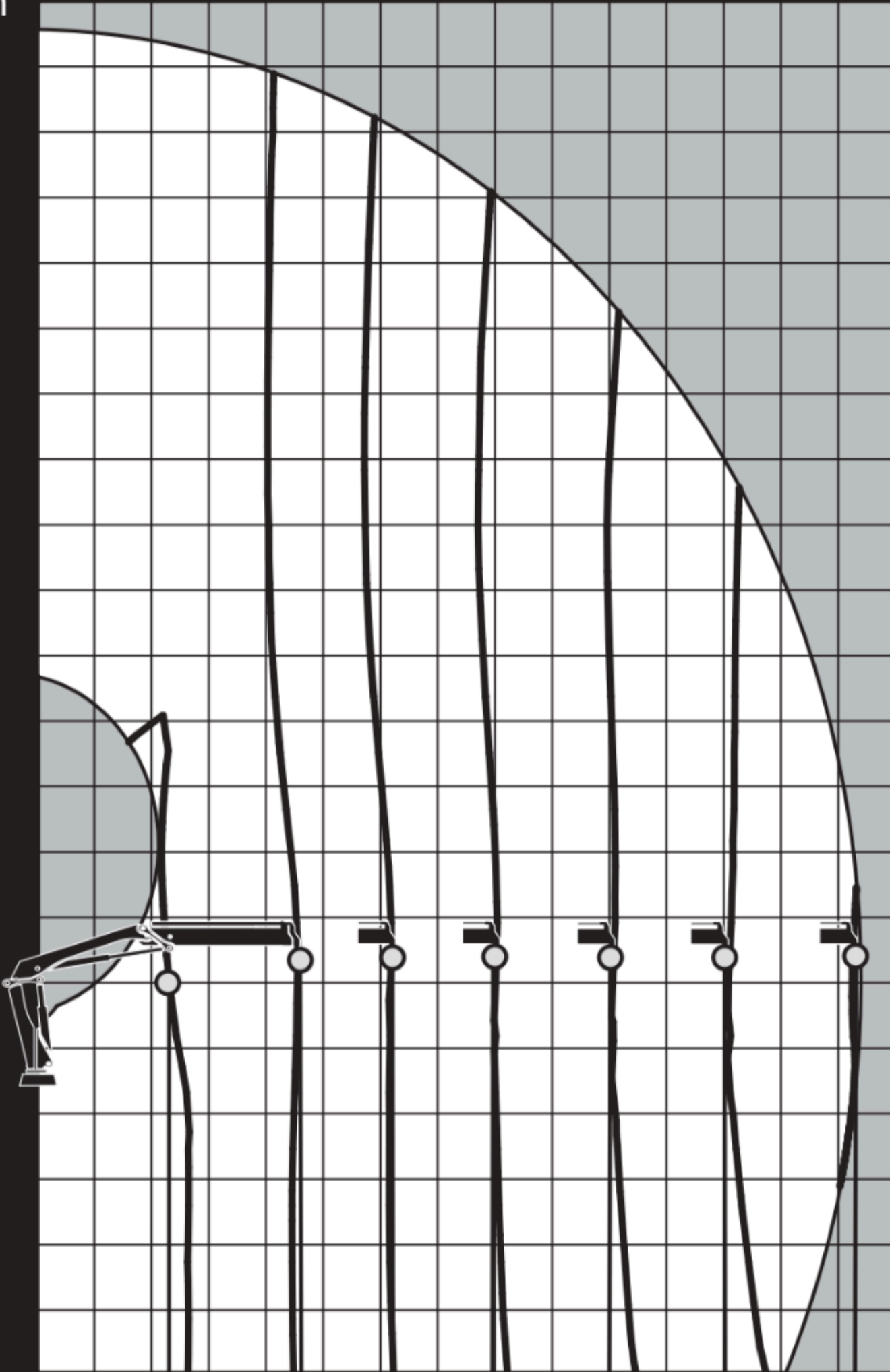

456-3305/1

ADC	3400	1920	1300	920	680	540	450
kg	3150	1760	1180	820	600	470	390

X-HIDUO 108 E-5

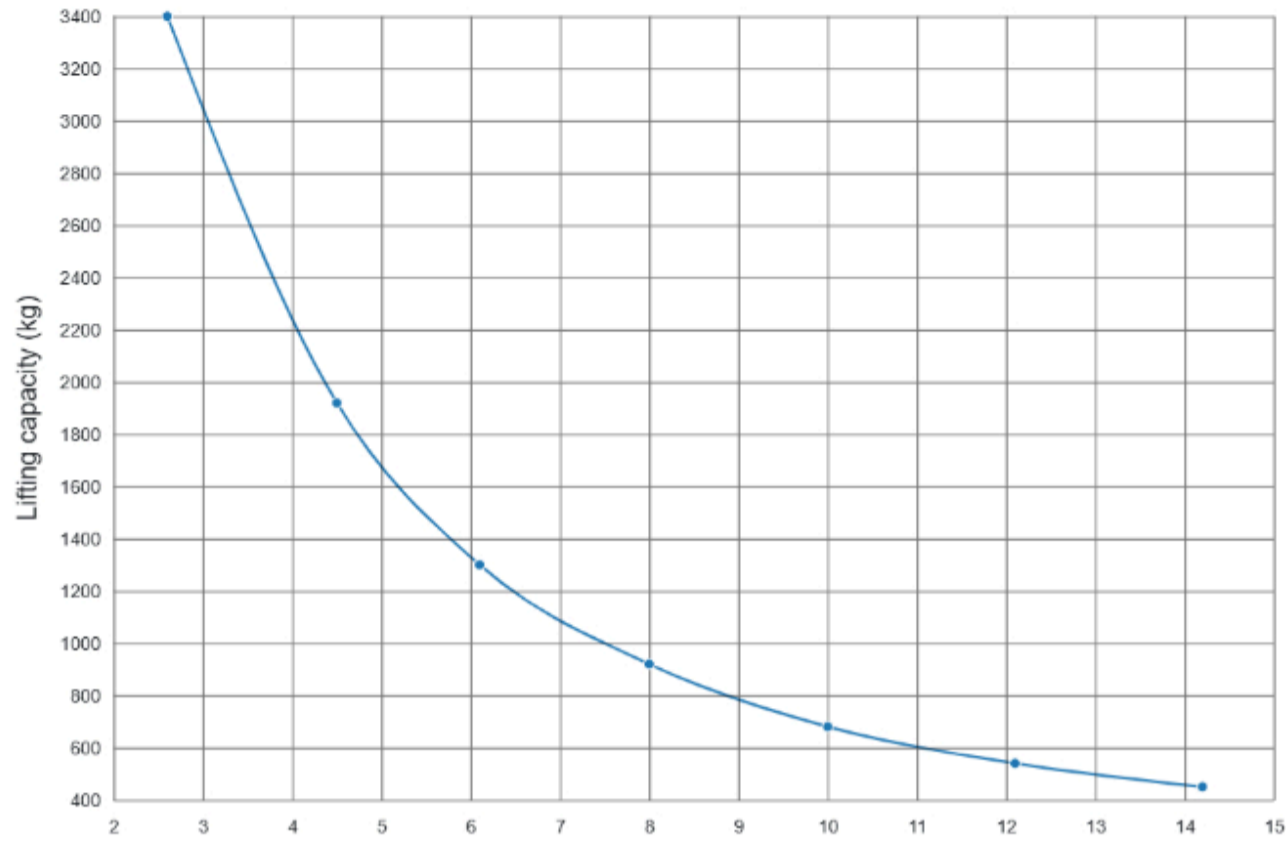

Outreach

Description	Unit	Value
Standard Outreach 1 (SOR1) - Standard load at std outreach with ADC 1 (SLC_ADC1)	m - kg	2.6 - 3400
Standard Outreach 2 (SOR2) - Standard load at std outreach with ADC 2 (SLC_ADC2)	m - kg	4.5 - 1920
Standard Outreach 3 (SOR3) - Standard load at std outreach with ADC 3 (SLC_ADC3)	m - kg	6.1 - 1300
Standard Outreach 4 (SOR4) - Standard load at std outreach with ADC 4 (SLC_ADC4)	m - kg	8.0 - 920
Standard Outreach 5 (SOR5) - Standard load at std outreach with ADC 5 (SLC_ADC5)	m - kg	10.0 - 680
Standard Outreach 6 (SOR6) - Standard load at std outreach with ADC 6 (SLC_ADC6)	m - kg	12.1 - 540
Standard Outreach 7 (SOR7) - Standard load at std outreach with ADC 7 (SLC_ADC7)	m - kg	14.2 - 450
HydOut Reach Std (HORS)	m	14.3
Hyd Boom Ext (HBE)	m	9.9

Lifting capacity

Description	Unit	Value
Max Dynamic Moment (Mdyn)	kNm	132.0
Lifting Capacity (LC_ADC_kNm)	kNm	85.0
Lifting Capacity (LC_ADC_kNm)	tm	8.7
Stress calculation moment (Mstat)	kNm	171.0

Oil and tank

Description	Unit	Value
Rec OilFlow Lo (Flow-Lo) - Rec OilFlow Hi (Flow-Hi)	l/min - l/min	45 - 55
Work Pressure (WP)	MPa	31.0

Slewing

Description	Unit	Value
Slewing Angle (SlewAng)	°	406
Max slope viable at full capacity (MaxAng)	°	4.5
Slewing Torque (SlewTorq)	kNm	10.7
Lift Speed (LiftSp)	m/s	2.0

Dimensions

Description	Unit	Value
Height fold. (3-1)	mm	2100.0
Ref 3-2 width folded- heartcrane frame left (3-3b)	mm	1150.0
Install.space need. (4-1)	mm	835.0

Weights

Description	Unit	Value
Weight of Crane (Weight)	kg	1580.0
add weight of frame attachment (add_WHT_FA)	kg	28.0
add weight of oil cooler (add_WHT_OC)	kg	23.0
Weight with legs (add_WHT_STAB)	kg	212.0

Total weight = 1843.0 kg