

# *SPECIFICATIONS*

SPEC. No. CC - 1150  
DATE APR. 2018

---

## **SPECIFICATIONS HYDRAULIC CRANE**

**MODEL: UNIC URW546C4ER**

Specifications are subject to change without notice.

---

**FURUKAWA UNIC CORPORATION**  
*EXPORT TECHNICAL DEPT*  
*TOKYO JAPAN*

**UNIC CRANE PERFORMANCE**  
**MODEL: URW546C4ER**

**CRANE CAPACITY:**

<b>LIFTING CAPACITY</b>	: Max. 4.05t at 2.5m
<b>HOOK HEIGHT</b>	
<b>ABOVE GROUND LEVEL</b>	: Max. 16.0m
<b>BELOW GROUND LEVEL</b>	: Max. 20.0m with 4-part line
<b>WORKING RADIUS</b>	: Min 0.66m, Max. 15.52m

**BOOM:** 6-section box beam type telescoping boom

Boom Length	
Retracted boom:	3.93m
Extended boom:	15.71m
Boom Extending Speed:	11.78m / 35s
Boom Raising Speed:	0° to 80° / 18s

**WINCH:** Hydraulic motor driven, spur gear reduction, with automatic mechanical brake and wire rope retaining roller.

Hoisting Speed	
Single line speed:	44.0m / min at 4th layer
Hook speed:	11.0m / min at 4th layer with 4-part line
Hook Block;	4.0t capacity, 2 sheaves with safety latch

Wire Rope	
Construction (JIS):	IWRC L6 x P-WS (26)
Diameter X Length:	8mm x 91.5m
Breaking strength:	53.0kN (5400kgf)

**SLEWING:** Hydraulic motor driven, worm gear reduction, spur gear reduction, and worm self-locking brake (supported by ball bearings)

Slewing Range:	360° continuous rotation on a ball bearing race
Slewing Speed:	2.5 rpm

**OUTRIGGERS:**

Horizontal:	A double acting hydraulic cylinder, direct pushing type (directly connected with hydraulic automatic lock device)
Vertical:	A double acting hydraulic cylinder, direct pushing type (directly connected with hydraulic automatic lock device)

## **HYDRAULIC SYSTEM:**

Hydraulic Pump	
Type:	Variable delivery piston pump
Rated pressure:	21.6MPa (220kgf/cm <sup>2</sup> )
Rated delivery:	60 ℓ /min.
Rated revolution:	2500rpm
Hydraulic oil tank:	75 ℓ capacity
Hydraulic Valves	
Control valve:	Multiple control valve, spring centered, spool-type, with pressure relief valve
Pressure relief valve setting:	For crawling: 21.6MPa (220kgf/cm <sup>2</sup> ) For crane: 20.6MPa (210kgf/cm <sup>2</sup> )
Counterbalance valve:	Boom raising and boom telescoping cylinders
Pilot-operated check valve:	Outrigger cylinders (Horizontal)
Double pilot-operated check valve:	Outrigger cylinders (Vertical)
Hydraulic Actuators	
Hydraulic motors:	Hoisting: Axial plunger type Slewing: Axial plunger type
Hydraulic cylinders:	Double acting type 1 X Boom raising cylinder 3 X Boom telescoping cylinder 4 X Outrigger cylinder (Horizontal) 4 X Outrigger cylinder (Vertical)

## **CRAWLING GEAR:**

Crawling:	Endless rubber crawler
Crawler:	300 mm × 52.5mm × 88 links
Tread length:	1750mm
Ground contact pressure:	46.1kPa (0.47kgf/cm <sup>2</sup> )
Crawling speed:	0~3km/h, forward/reverse
Hill climbing ability:	23°
Engine:	Rated output: 15.2kW (20.7ps)/2500rpm Model: 3TNV80F-SNFK (Yanmar Co.,Ltd)
	Displacement: 1266 cm <sup>3</sup>
	Fuel Type: Diesel Oil
Steering:	Hydraulic drive independent of left/right
Parking brake:	Disc brake with hydraulic motor built-in
Starter:	Starter motor
Fuel tank:	40 ℓ capacity

**Note:** The figures in relation to the speed are on the basis of no-load running at rated oil flow condition.

**SAFETY DEVICES:**

1. Pressure relief valve for hydraulic circuit
2. Counterbalance valves for boom raising and boom telescoping cylinders
3. Pilot-operated check valves for outrigger cylinders (Horizontal)
4. Double pilot-operated check valves for outrigger cylinders (Vertical)
5. Boom angle indicator with load indicator
6. Hook safety latch
7. Automatic mechanical brake for winch
8. Automatic stop for overwinding
9. Overwinding alarm
10. Automatic stop for leaving minimum wire rope
11. Emergency stop button
12. Inter-lock device of crane and crawling levers
13. Inter-lock device of crane and outriggers  
(Option: Outrigger ground contact detector)
14. Level
15. Three colored lamp
16. Head light

**VOICE MESSAGE:**

- [Remote control active]
- [Stop winch up]
- [Secure lifting hook]
- [Low transmitter battery]
- [Service remote control]
- [Reset main switch]
- [Change control mode]
- [Crane mode]
- [Outrigger mode Outriggers moving]
- [Check error code]
- [Control system error]

**DIMENSIONS OF CRANE:**

4870mm (L) X 1380mm (W) X 2035mm (H)

**MASS OF CRANE:**

4940kg

**REMOTE CONTROLLER:** (Radio controller model or Cable remote controller model)

Model:	RC-500HA-AUS		
System:	Manual/remote control combined system		
Control:	1. Selective control	Boom	Raise / Lower (Crane mode/Outrigger mode) Outrigger④ Ret / Ext
		Hook	Hoist / Lower (Shock-less ON / OFF) Outrigger③ Ret / Ext
		Boom	Extend / Retract (Outrigger Horizontal /Vertical) Outrigger② Ret / Ext
		Slewing	C.W / C.C.W (Eng. start / stop) Outrigger① Ret / Ext
	2. Store hook	Hook storage	
	3. Start/Warning horn	Start radio remote control and recovered emergency stop/ Horn	
	4. Speed control lever	Hydraulic control and engine speed control	
	5. Mode select	Crane mode/Outrigger mode (Shock-less ON/OFF) Outrigger horizontal/vertical (Engine Start / Stop)	
	6. Speed mode select	High speed mode (normal mode)/ Medium speed mode/Low speed mode	
	7. Key switch	Transmitter power on-off	
	8. Emergency-stop switch	Stop function of crane	
Power supply:	Controller	Crawler battery (DC12V)	
	Transmitter	Four R03 dry cells (DC6V)	
Power consumption:	Approx. 50 W (Single selective operation at maximum operating speed)		
Transmitter:	Battery life more than 20 hours (of transmitter operation)		
Transmitter weight:	700g (with batteries)		
Ambient temperature:	-20 °C ~ +60 °C		
Storage temperature:	-30 °C ~ +75 °C		

**RADIO:** (Radio remote controller model)

Radio frequency:	433 ~ 434 MHz Band
Transmitted output power:	10mW
Operating range:	Approx. 100m
Unit address:	Special address combining a frequency and ID code is assigned to each unit.

**Caution**

In accordance with our policy of constant product improvement, all specifications are subject to change without notice or obligations.

**WORKING RANGE:**

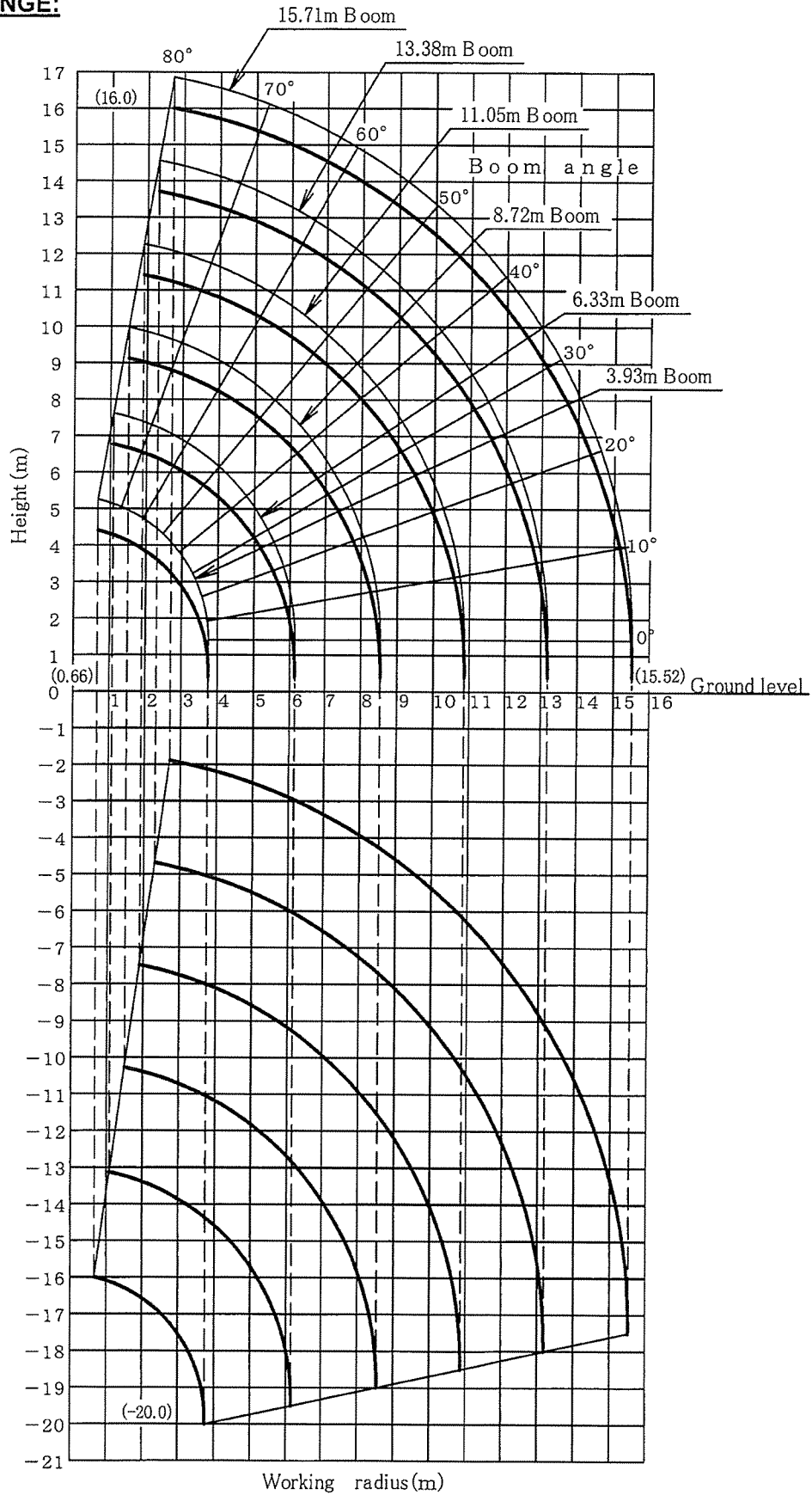

**Note:** The above figures are based on no-load condition and do not include the deflection of the boom.

**NET RATED LOADS:**

Boom-sections extended: ①, ①+②

Working radius (m)		2.5	3.0	3.5	4.0	4.5	5.0	5.5	6.0	6.14
Net Rated load ( t )	Outriggers extended to maximum	4.0	3.45	3.0	2.55	2.25	2.0	1.8	1.63	1.6
	Outriggers extended to halfway	4.0	3.45	3.0	2.45	2.1	1.85	1.7	1.4	1.35
	Outriggers extended to minimum	4.0	3.45	3.0	2.4	2.0	1.65	1.35	1.1	1.0

Boom-sections extended: ①+②+③

Working radius (m)		3.5	4.0	4.5	5.0	5.5	6.0	6.5	7.0	7.5	8.0	8.53
Net Rated load ( t )	Outriggers extended to maximum	3.0	2.55	2.25	2.0	1.8	1.65	1.5	1.35	1.2	1.1	1.0
	Outriggers extended to halfway	3.0	2.4	2.1	1.85	1.7	1.4	1.2	1.05	0.85	0.75	0.62
	Outriggers extended to minimum	3.0	2.4	2.0	1.65	1.35	1.1	0.9	0.75	0.6	0.5	0.45

Boom-sections extended: ①+②+③+④

Working radius (m)		4.0	4.3	4.5	5.0	5.5	6.0	7.0	8.0	9.0	10.0	10.9
Net Rated load ( t )	Outriggers extended to maximum	2.0	2.0	1.88	1.68	1.5	1.35	1.15	1.0	0.9	0.78	0.65
	Outriggers extended to halfway	2.0	2.0	1.8	1.6	1.45	1.3	1.05	0.7	0.6	0.45	0.39
	Outriggers extended to minimum	2.0	2.0	1.8	1.6	1.35	1.1	0.75	0.5	0.4	0.3	0.25

Boom-sections extended: ①+②+③+④+⑤

Working radius (m)		5.0	5.5	6.0	7.0	8.0	9.0	10.0	11.0	12.0	13.2
Net Rated load ( t )	Outriggers extended to maximum	1.1	0.95	0.86	0.71	0.6	0.55	0.5	0.45	0.4	0.35
	Outriggers extended to halfway	1.1	0.95	0.86	0.7	0.6	0.52	0.45	0.39	0.3	0.25
	Outriggers extended to minimum	1.1	0.95	0.86	0.7	0.5	0.4	0.3	0.25	0.2	0.17

Boom-sections extended: ①+②+③+④+⑤+⑥

Working radius (m)		6.0	7.0	8.0	9.0	10.0	11.0	12.0	13.0	14.0	15.0	15.52
Net Rated load ( t )	Outriggers extended to maximum	0.86	0.71	0.6	0.55	0.5	0.44	0.39	0.33	0.27	0.21	0.16
	Outriggers extended to halfway	0.86	0.5	0.35	0.3	0.27	0.25	0.22	0.2	0.17	0.16	0.15
	Outriggers extended to minimum	0.86	0.5	0.35	0.3	0.25	0.23	0.2	0.17	0.15	0.12	0.1

## CAUTION

1. Net rated loads are performance when the crane is placed level and is based on an actual working radius including boom deflection under load.  
Net rated loads are also based on the strength of the crane and the stability of the crawler.
2. Net rated loads must be reduced in accordance with wind, ground condition and operating speed.
3. Net rated loads are the lifting capacities excepted for the mass of the hook.
4. The mass of the slings and any accessories attached to the boom or load line must be deducted from the above net rated loads in the chart.
5. When the outriggers are set without extending to their maximum, stability of the crane deteriorates remarkably.  
Pay attention that the net rated loads are changed according to how far the outriggers are extended.
6. If any one of the four outriggers is not fully extended, operate with performance of not maximum extension.
7. In order to make correct operation, read the instruction manual carefully before crane operation.



**FLY JIB:(OPTION)**

LIFTING CAPACITY: 710kg  
 JIB LENGTH: 2.0m  
 TILT ANGLE: 0° ,20° ,40° ,60°  
 MASS OF FLY JIB: 95kg

**NET RATED LOADS: (FOR FLY JIB)**

BOOM ANGLE	TILT ANGLE							
	1st TO 5th BOOM SECTIONS				ONLY 6th BOOM SECTION			
	0°	20°	40°	60°	0°	20°	40°	60°
80°	700	700	700	700	350	350	350	350
75°	700	700	700	700	350	350	350	350
70°	600	600	550	550	300	300	250	250
65°	450	450	350	350	200	200	150	150
60°	250	250	200	200	100	100	100	100
55°	150	150	PROHIBITED AREA OF CRANE OPERATIONS		PROHIBITED AREA OF CRANE OPERATIONS			
50°	100	100						
40°	PROHIBITED AREA OF CRANE OPERATIONS							
30°								
20°								
10°								
0°	PROHIBITED AREA OF CRANE OPERATIONS							

**CAUTION**

1. Net rated loads are performance when outriggers extended to maximum.
2. Net rated loads are performance when the crane is placed level and is based on an actual working radius including boom deflection under loaded.  
Net rated loads are also based on strength and stability of the crane.
3. Net rated loads must be reduced in accordance with wind, ground condition and operating speed.
4. Net rated loads are the lifting capacities except for the mass of hook.
5. The mass of the slings and any accessories attached to the boom or load line must be deducted from the above net rated loads in the chart.
6. In order to make correct operation, read the instruction manual carefully before crane operation.

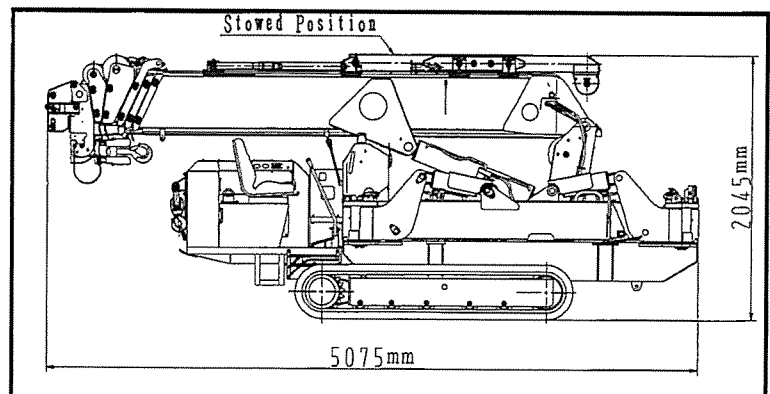
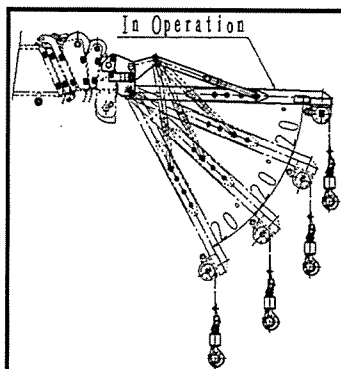

**WORKING RANGE:**  
(FOR FLY JIB)

**WORKING RANGE CHART (FOR EXTENSION JIB)**

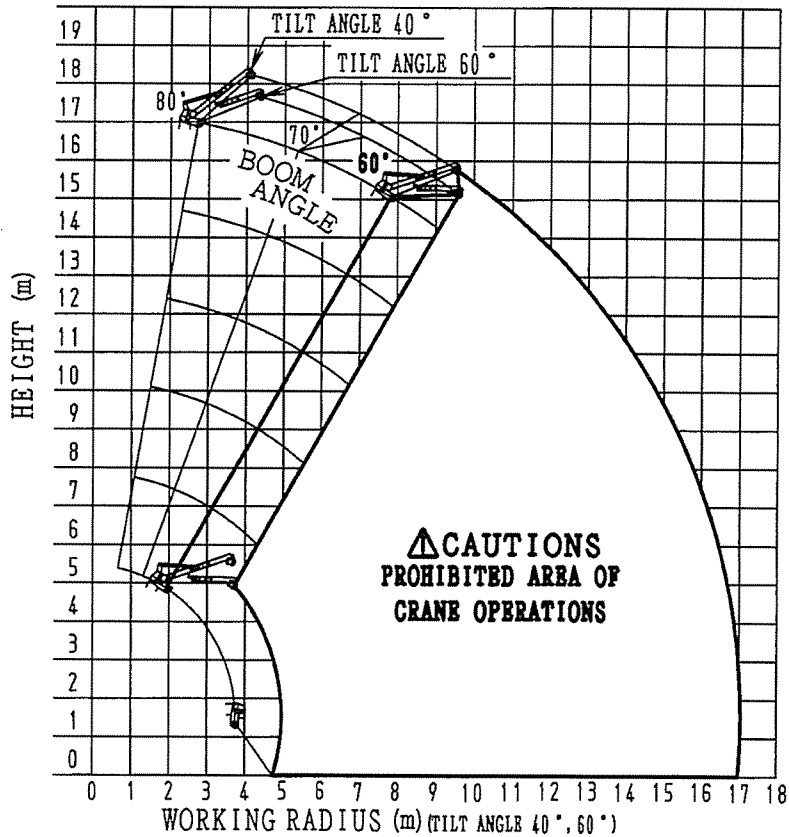
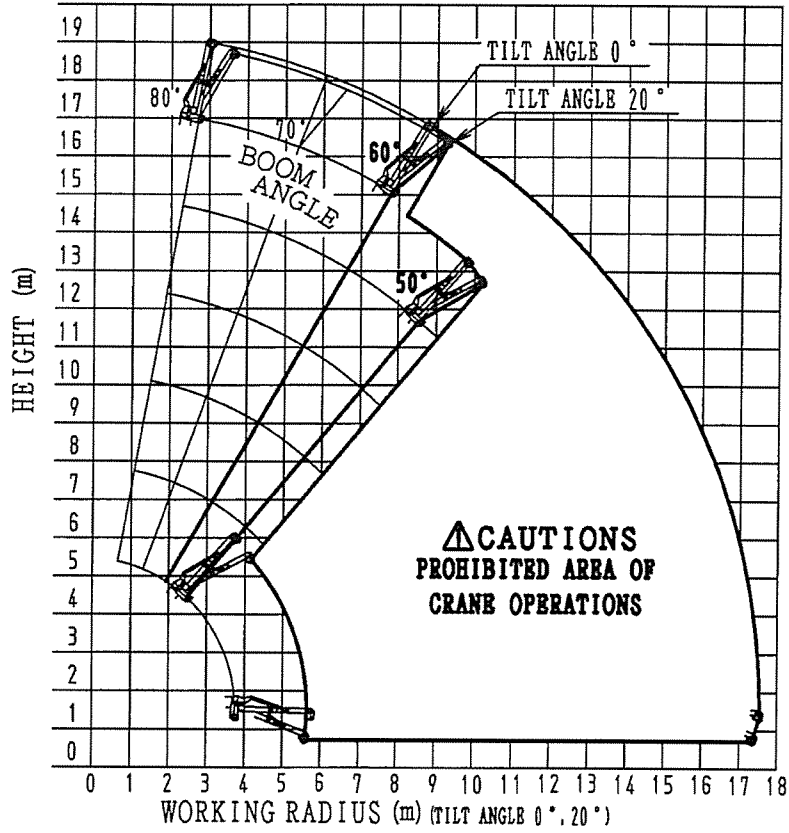

**Note:** The above figures are based on no-load condition and do not include the deflection of the boom.

**FLY JIB-SEARCHER HOOK :(OPTION)**

LIFTING CAPACITY: 700kg  
 SEARCHER HOOK LENGTH: 2.0m  
 TILT ANGLE: 0° ,20° ,40° ,60°  
 MASS OF SEARCHER HOOK 8kg (Bracket and jib are excepted)

**NET RATED LOADS: (FOR FLY JIB-SEARCHER HOOK)**

1st TO 5th BOOM SECTIONS				ONLY 6th BOOM SECTION				
NET RATED LOAD(kg)				NET RATED LOAD(kg)				
WIRKING RADIUS (m)	OUTRIG. EXT. TO MAX.	OUTRIG. EXT. TO HALF.	OUTRIG. EXT. TO MIN.	WIRKING RADIUS (m)	OUTRIG. EXT. TO MAX.	OUTRIG. EXT. TO HALF.	OUTRIG. EXT. TO HALF.	
5.0	700	700	700	6.0	350	350	350	
6.0	600	600	600	7.0	250	250	250	
7.0	450	450	450	8.0	200	200	200	
8.0	300	300	300	9.0	100	100	100	
9.0	250	200	200	10.0	PROHIBITED AREA OF CRANE OPERATION			
10.0	150	100	100	11.0				
11.0	100	PROHIBITED AREA OF CRANE OPERATION		12.0				
12.0	PROHIBITED AREA OF CRANE OPERATION			13.0				
13.0				14.0				
14.0				15.0				
15.0				16.0				
15.21				17.0				
								17.54

**CAUTION**

1. Net rated loads are performance when the crane is placed level and is based on an actual working radius including boom deflection under loaded.  
 Net rated loads are also based on strength and stability of the crane.
2. Net rated loads must be reduced in accordance with wind, ground condition and operating speed.
3. The mass of the slings and any accessories attached to the boom or load line must be deducted from the above net rated loads in the chart.
4. In order to make correct operation, read the instruction manual carefully before crane operation.
5. Do not use the main hook when using the searcher hook.

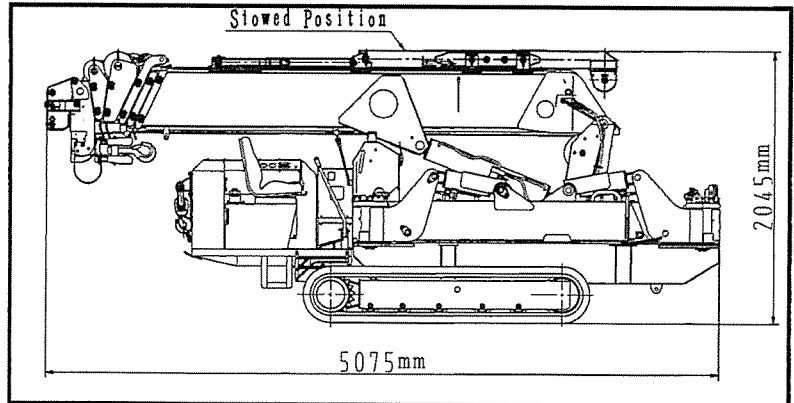
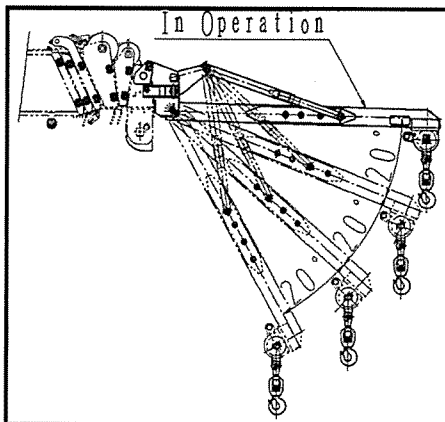

**SEARCHER HOOK :(OPTION)**

LIFTING CAPACITY: 500kg  
 SEARCHER HOOK LENGTH: 0.8m  
 TILT ANGLE: 0° ,20° ,40° ,60°  
 MASS OF SEARCHER HOOK: 20kg

**NET RATED LOADS: (FOR SEARCHER HOOK)**

1st TO 5th BOOM SECTIONS				ONLY 6th BOOM SECTION			
NET RATED LOAD (kg)				NET RATED LOAD (kg)			
WORKING RADIUS (m)	OUTRIG. EXT. TO MAX.	OUTRIG. EXT. TO HALF.	OUTRIG. EXT. TO MIN.	WORKING RADIUS (m)	OUTRIG. EXT. TO MAX.	OUTRIG. EXT. TO HALF.	OUTRIG. EXT. TO MIN.
2.0	500	500	500	2.0	480	480	480
3.0	500	500	500	3.0	480	480	480
4.0	500	500	500	4.0	480	480	480
5.0	500	500	500	5.0	480	480	480
6.0	500	500	500	6.0	480	480	480
7.0	500	500	500	7.0	360	360	360
8.0	500	500	450	8.0	300	300	300
9.0	500	470	350	9.0	250	250	250
10.0	450	400	250	10.0	220	220	220
11.0	400	330	200	11.0	200	200	180
12.0	350	250	150	12.0	170	170	150
13.0	300	200	130	13.0	150	150	130
13.99	250	150	100	14.0	120	120	100
				15.0	100	100	80
				16.32	80	80	50

**CAUTION**

1. Net rated loads are performance when the crane is placed level and is based on an actual working radius including boom deflection under loaded.  
 Net rated loads are also based on strength and stability of the crane.
2. Net rated loads must be reduced in accordance with wind, ground condition and operating speed.
3. The mass of the slings and any accessories attached to the boom or load line must be deducted from the above net rated loads in the chart.
4. In order to make correct operation, read the instruction manual carefully before crane operation.
5. Do not use the main hook when using the searcher hook.

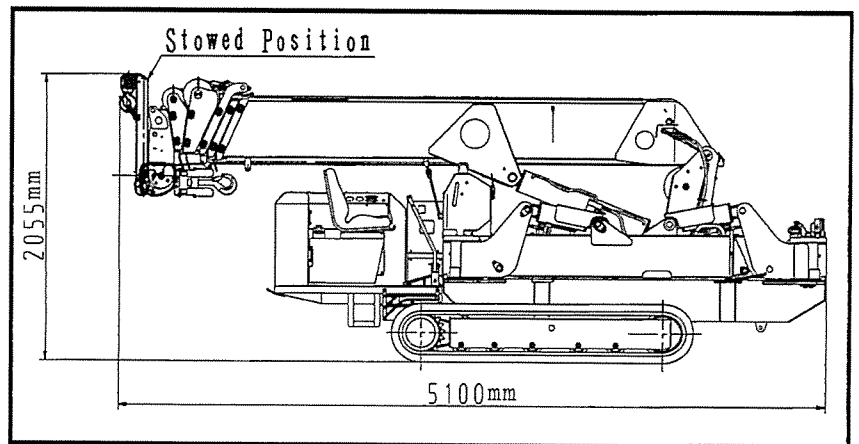
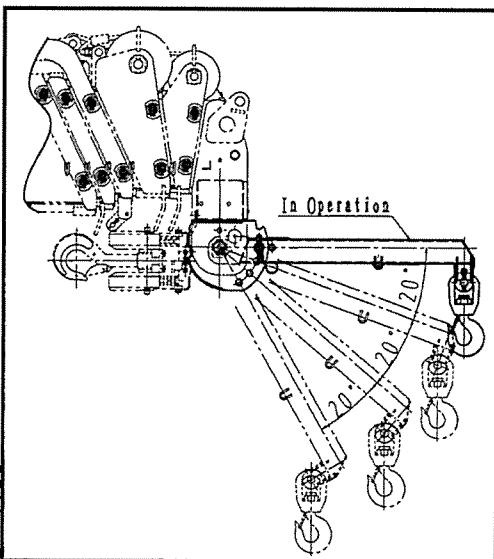

CC-1150

CC-1150

